

ANT

FREEFLIGHT $\frac{1}{2}$ Inch

MONOV AN-2 (COLT

to One Foot Scale FLYING MODEL f

)

for 1 cc Motor

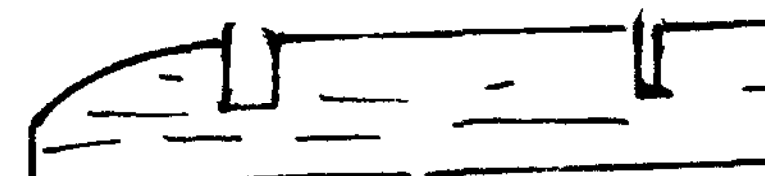



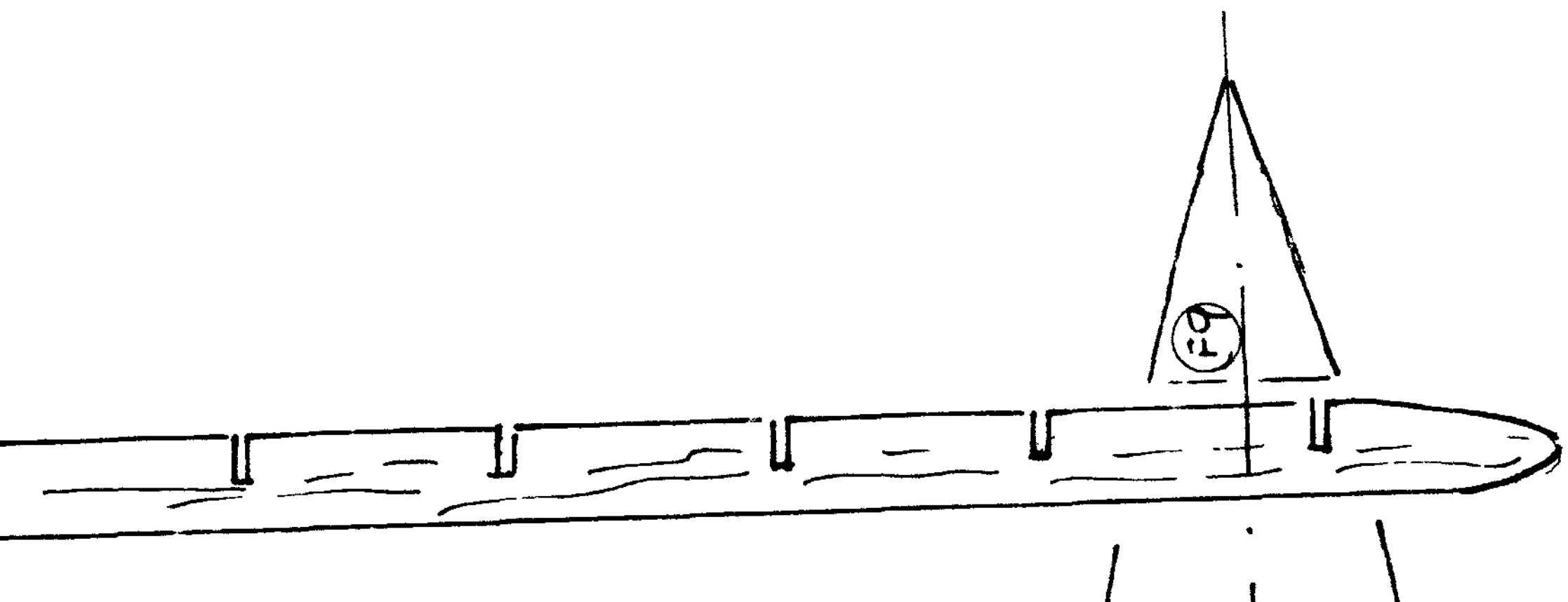

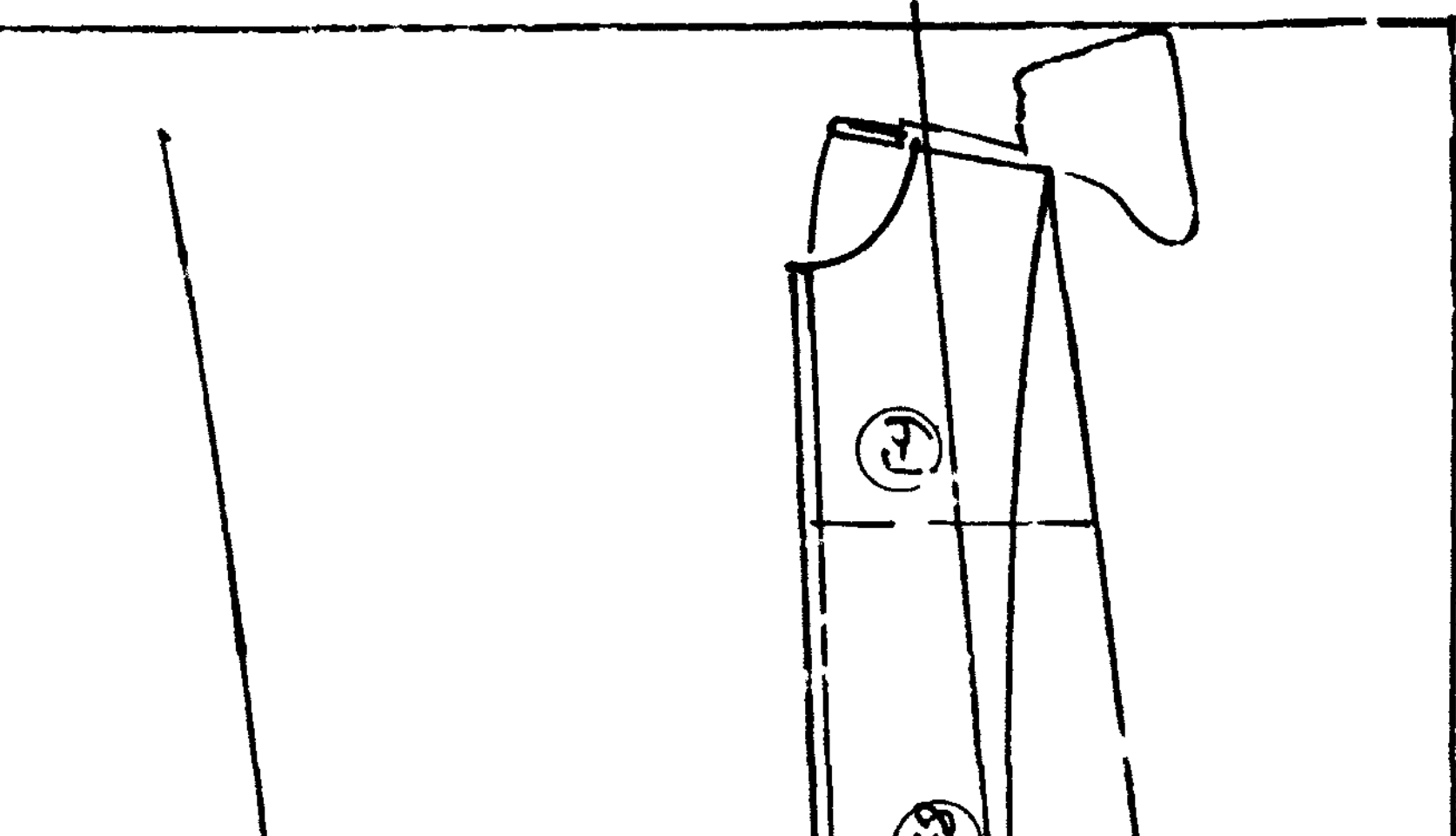



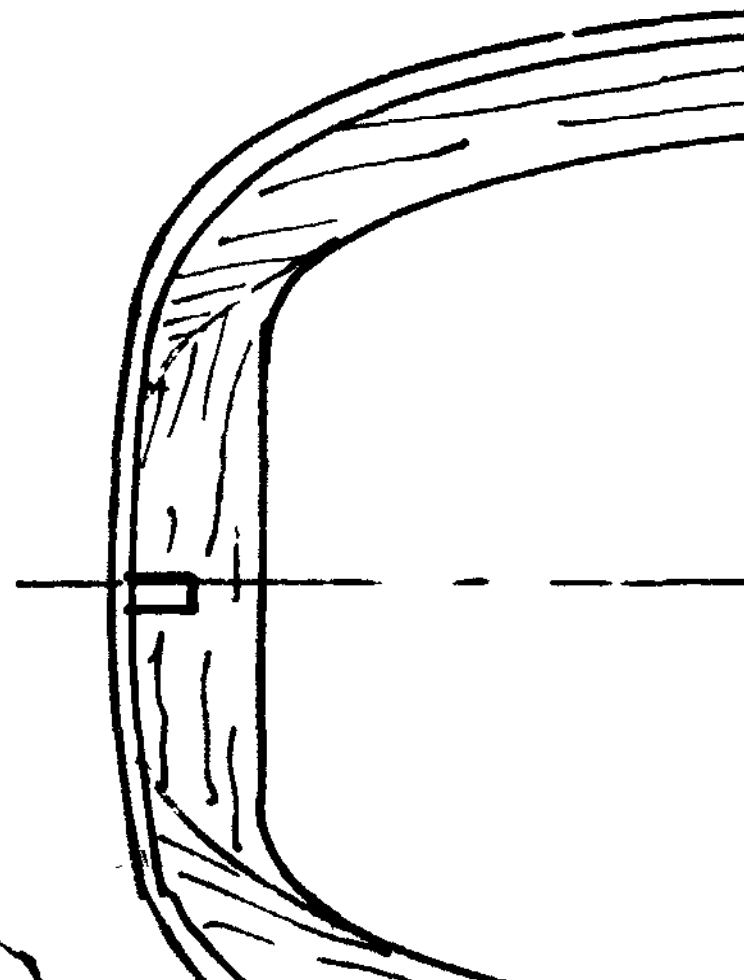
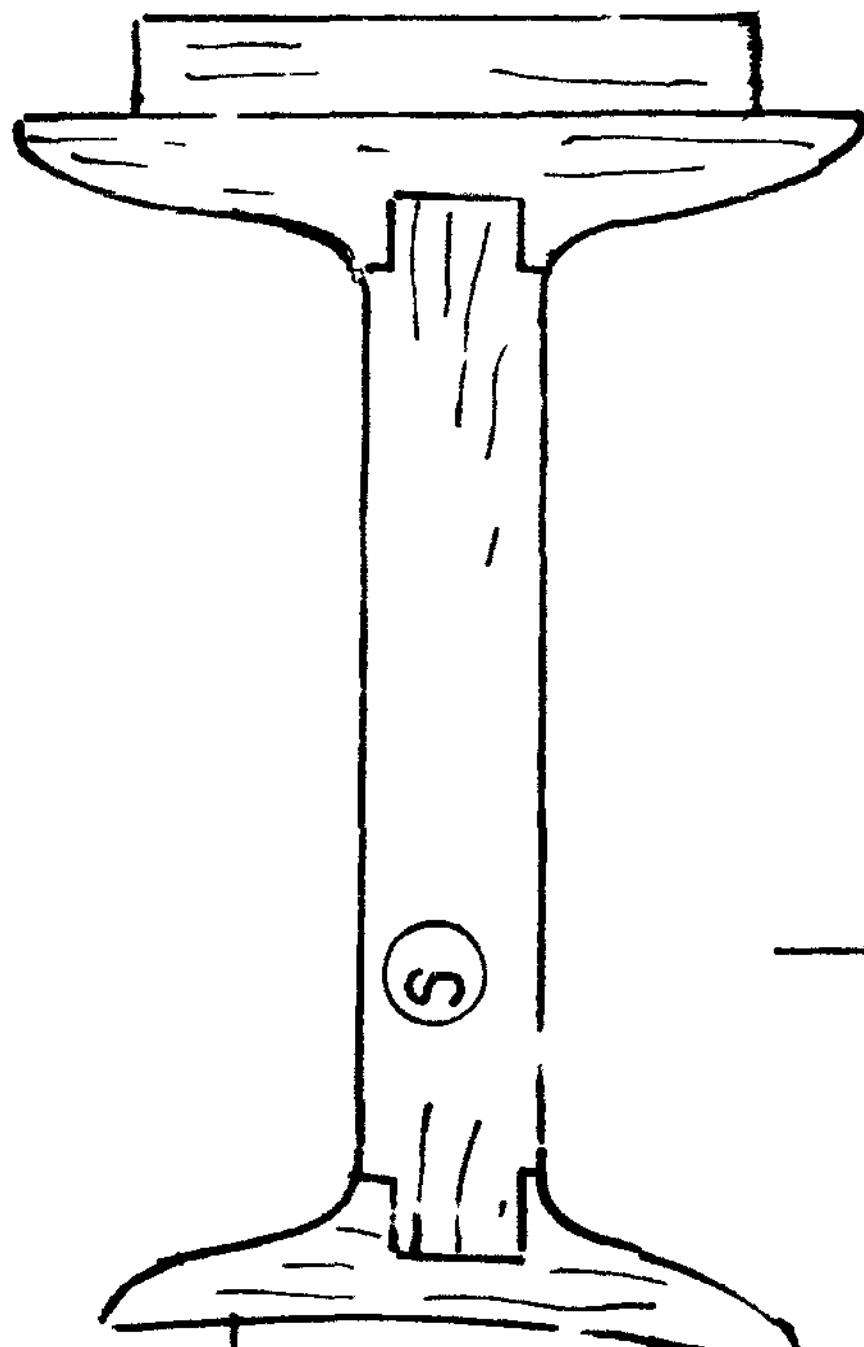
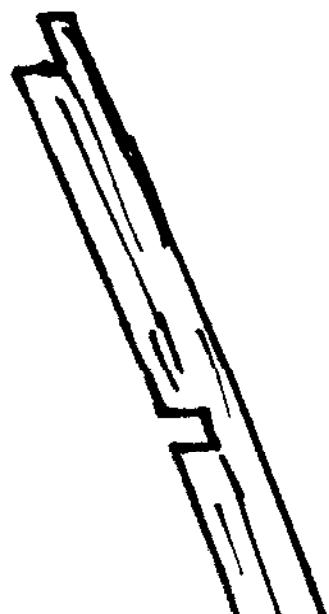

Designed Built and

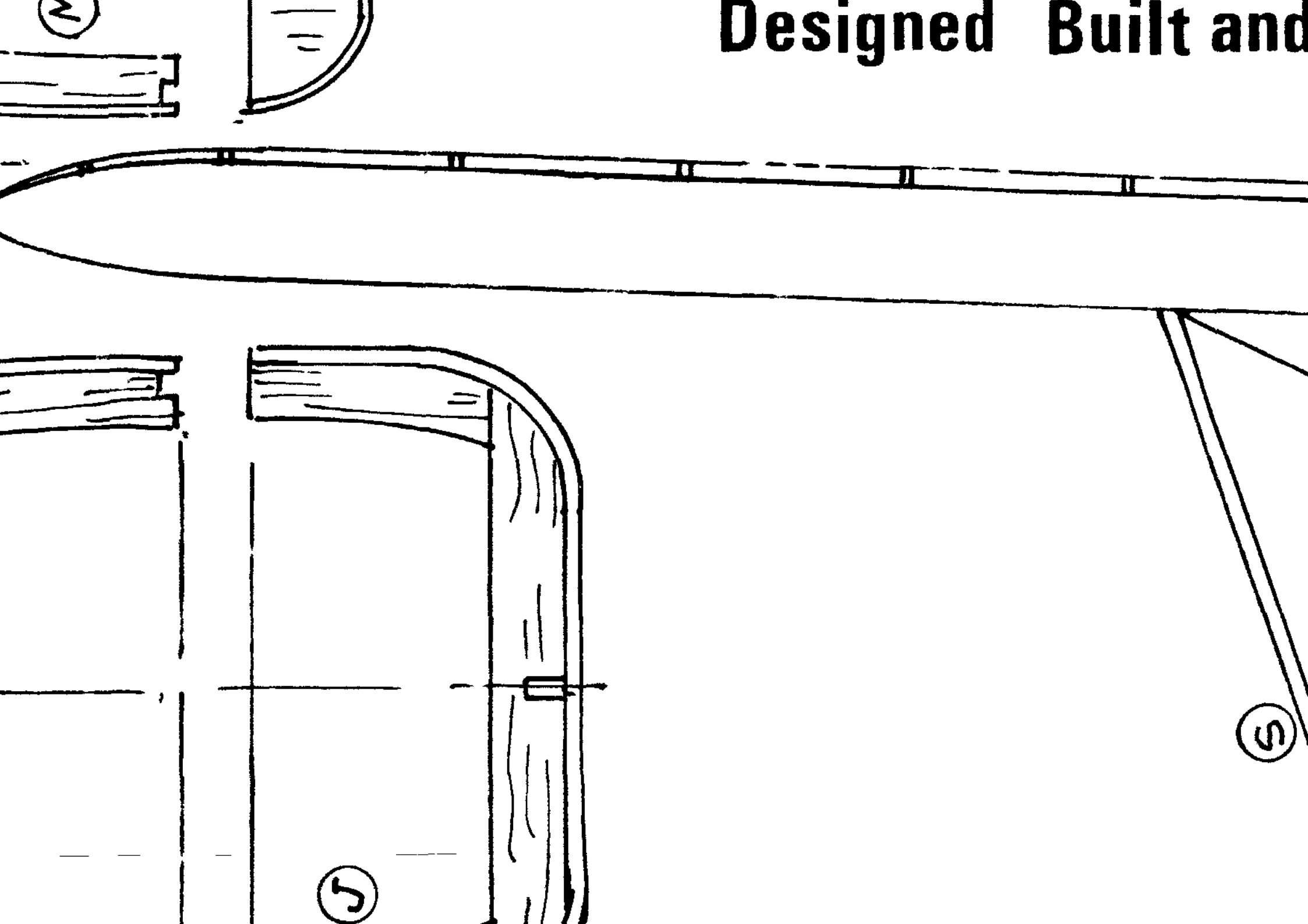

Drawn by

Harold J. Iowner.

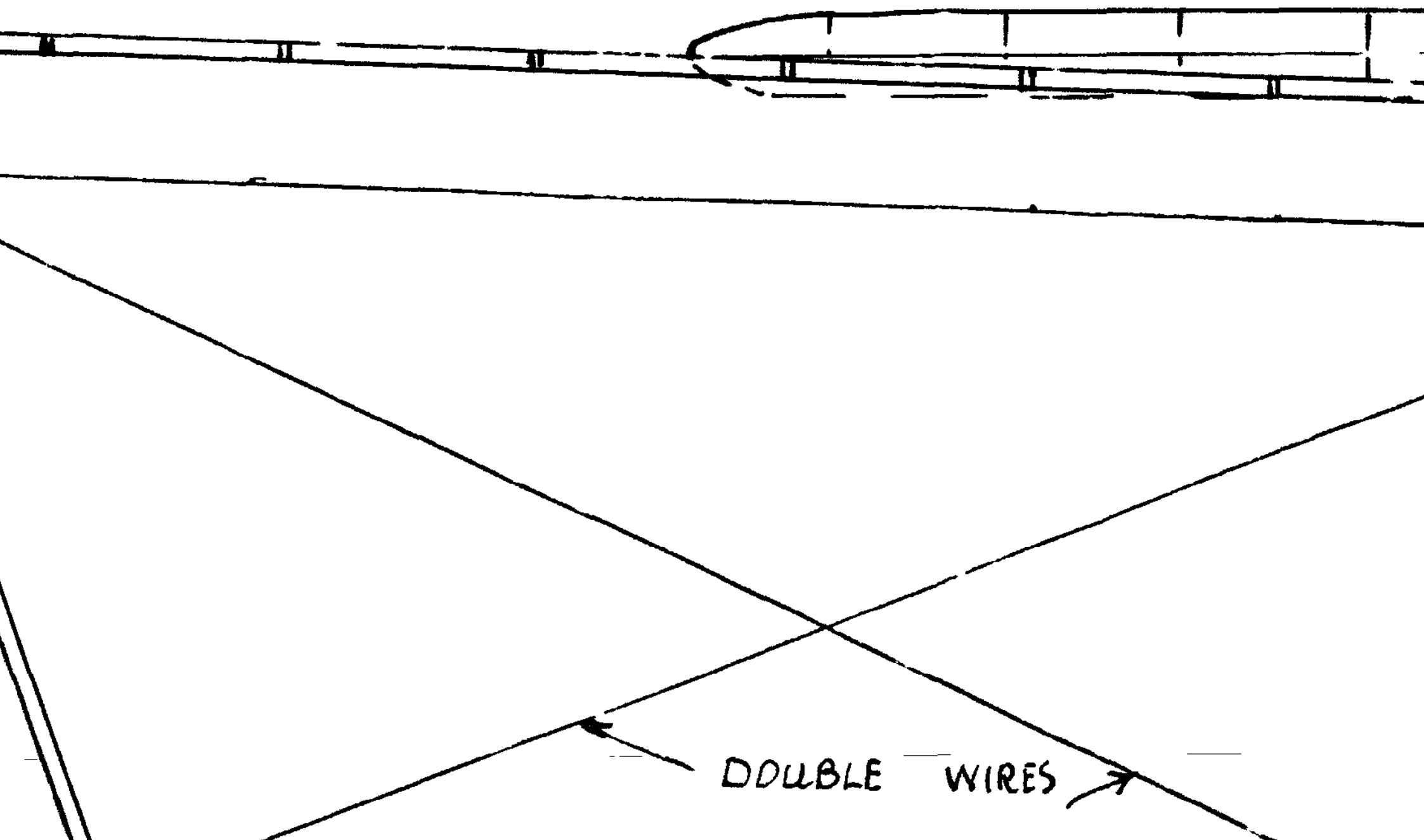

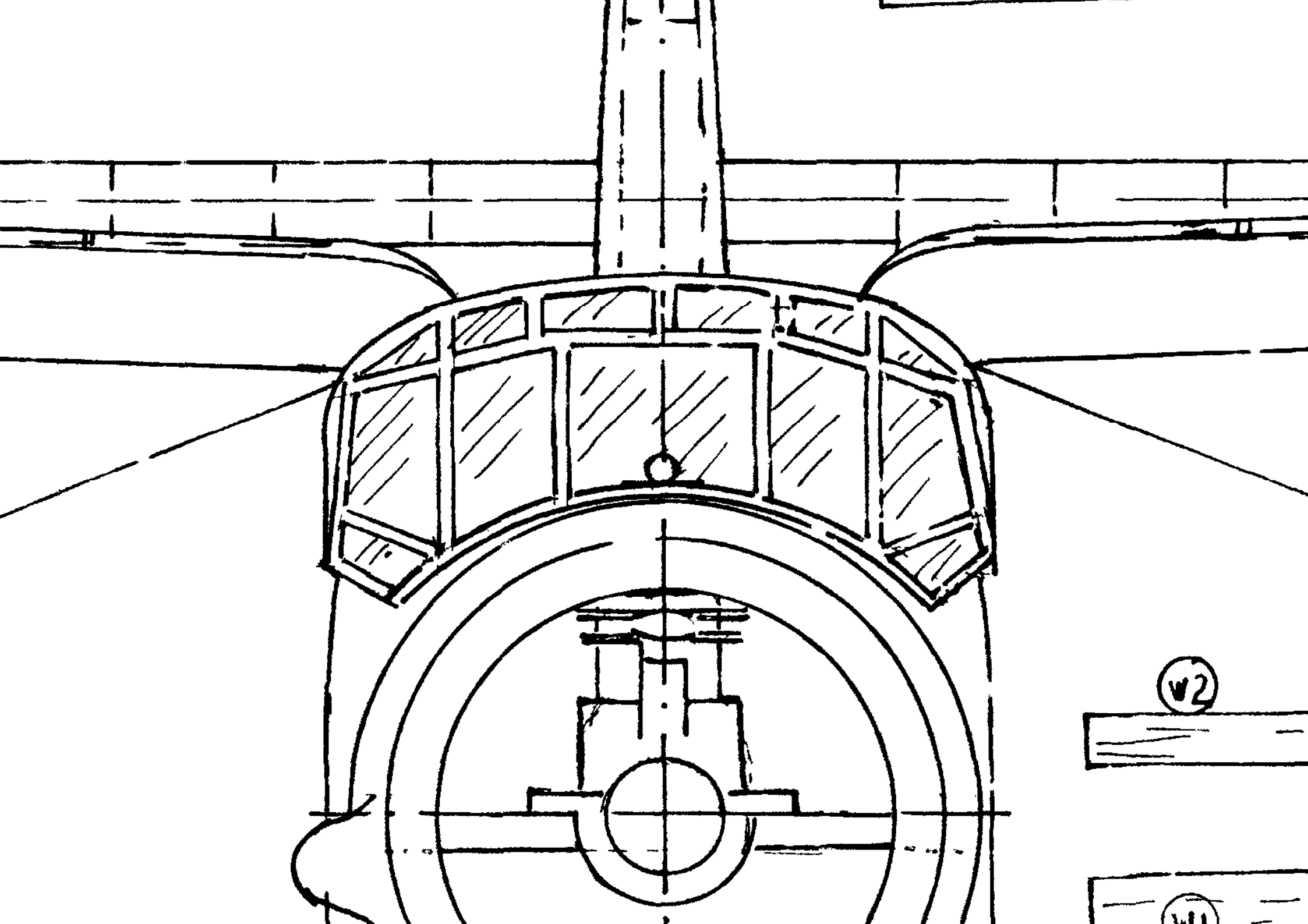

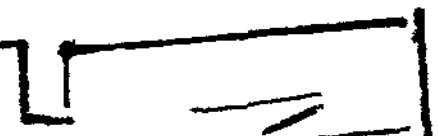
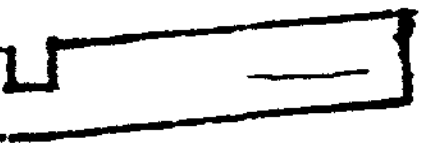
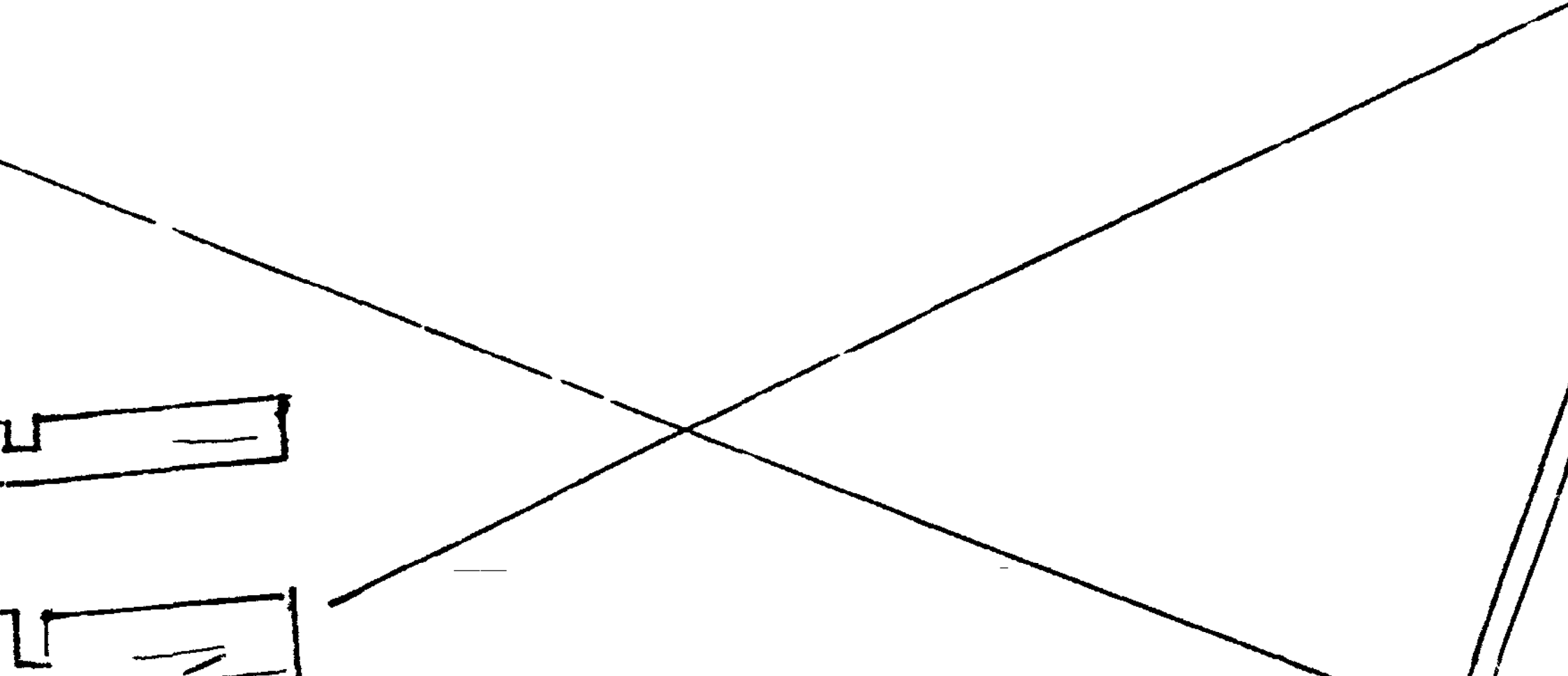

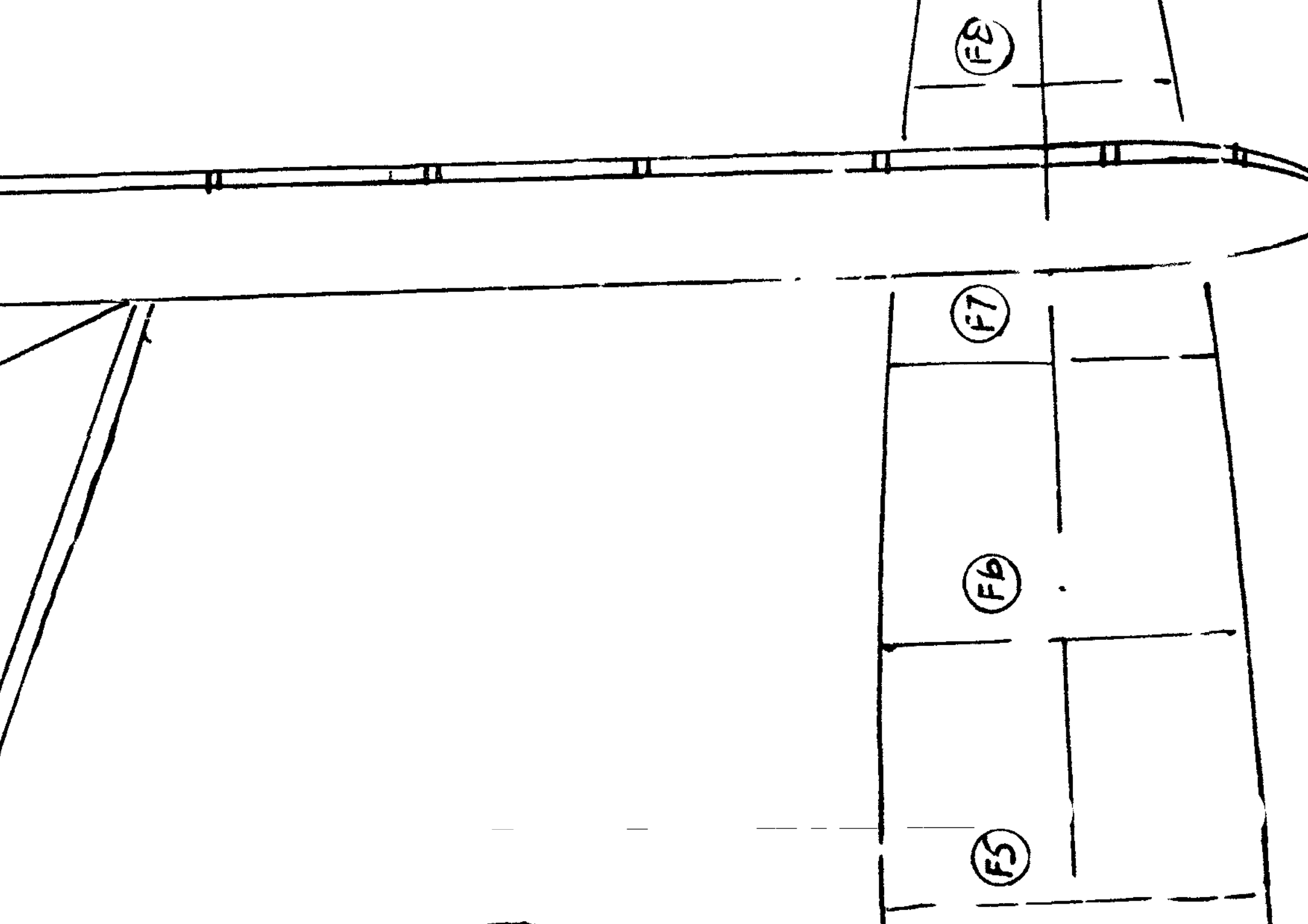

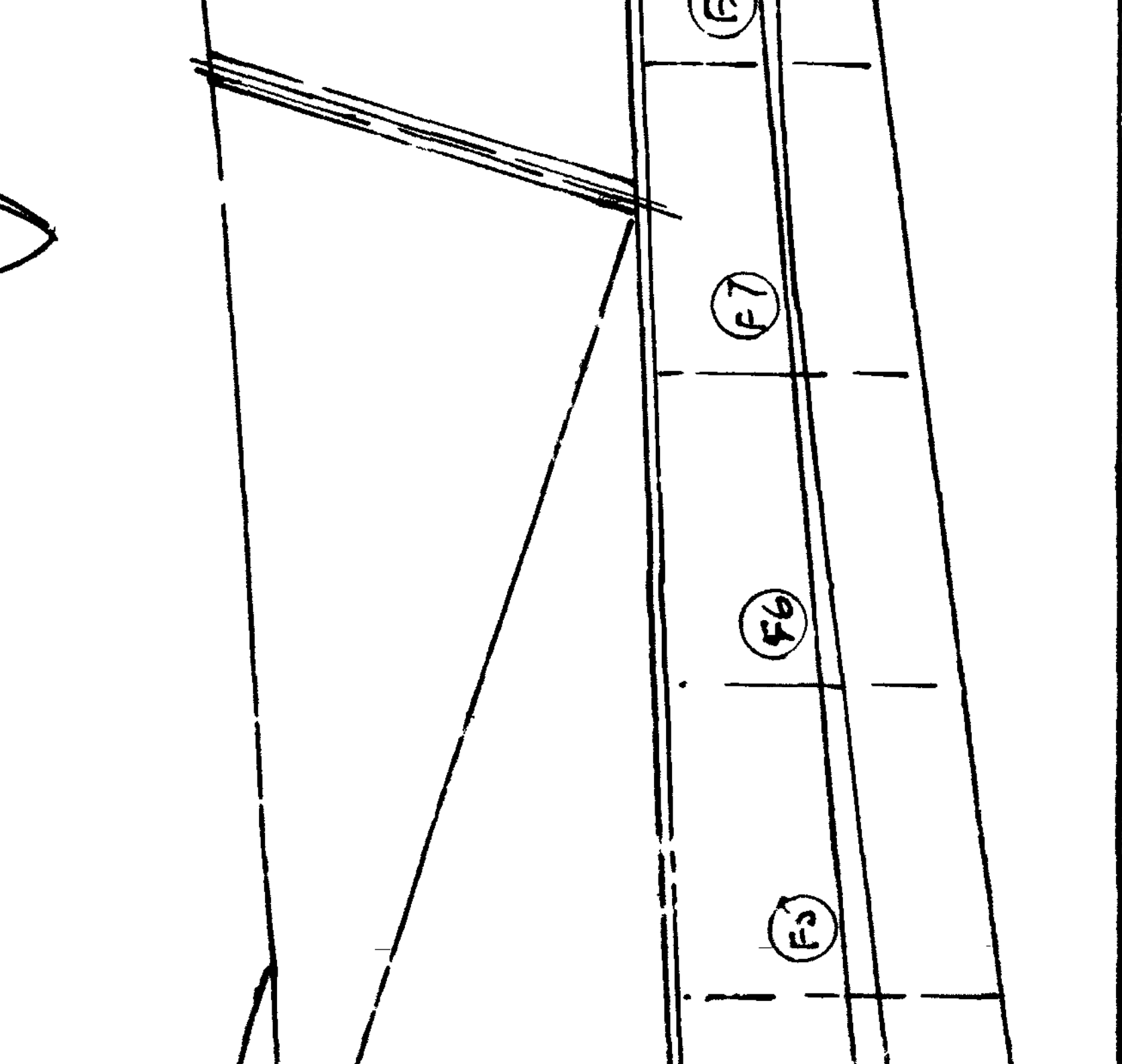

F5

F6

F7

F8

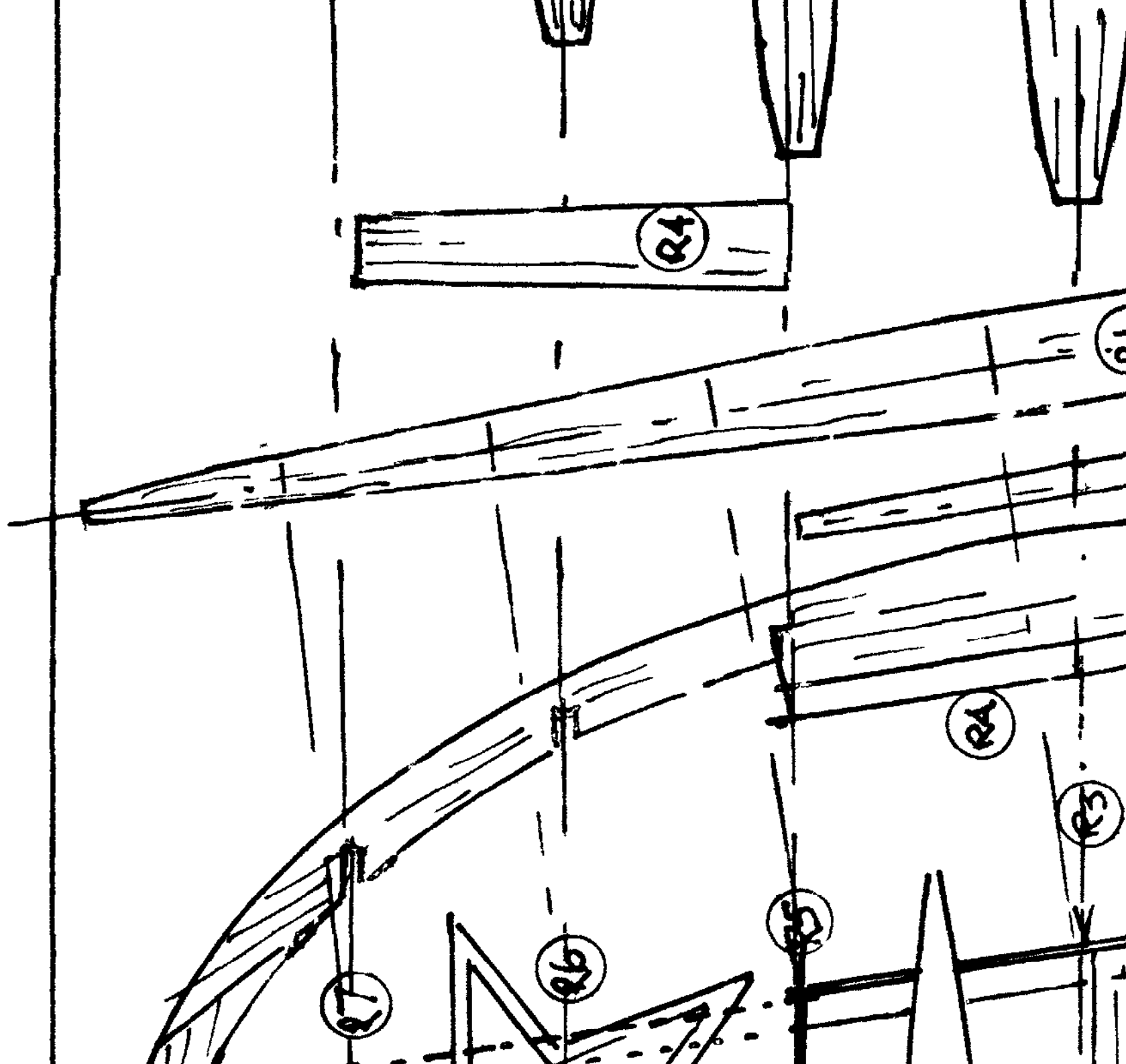

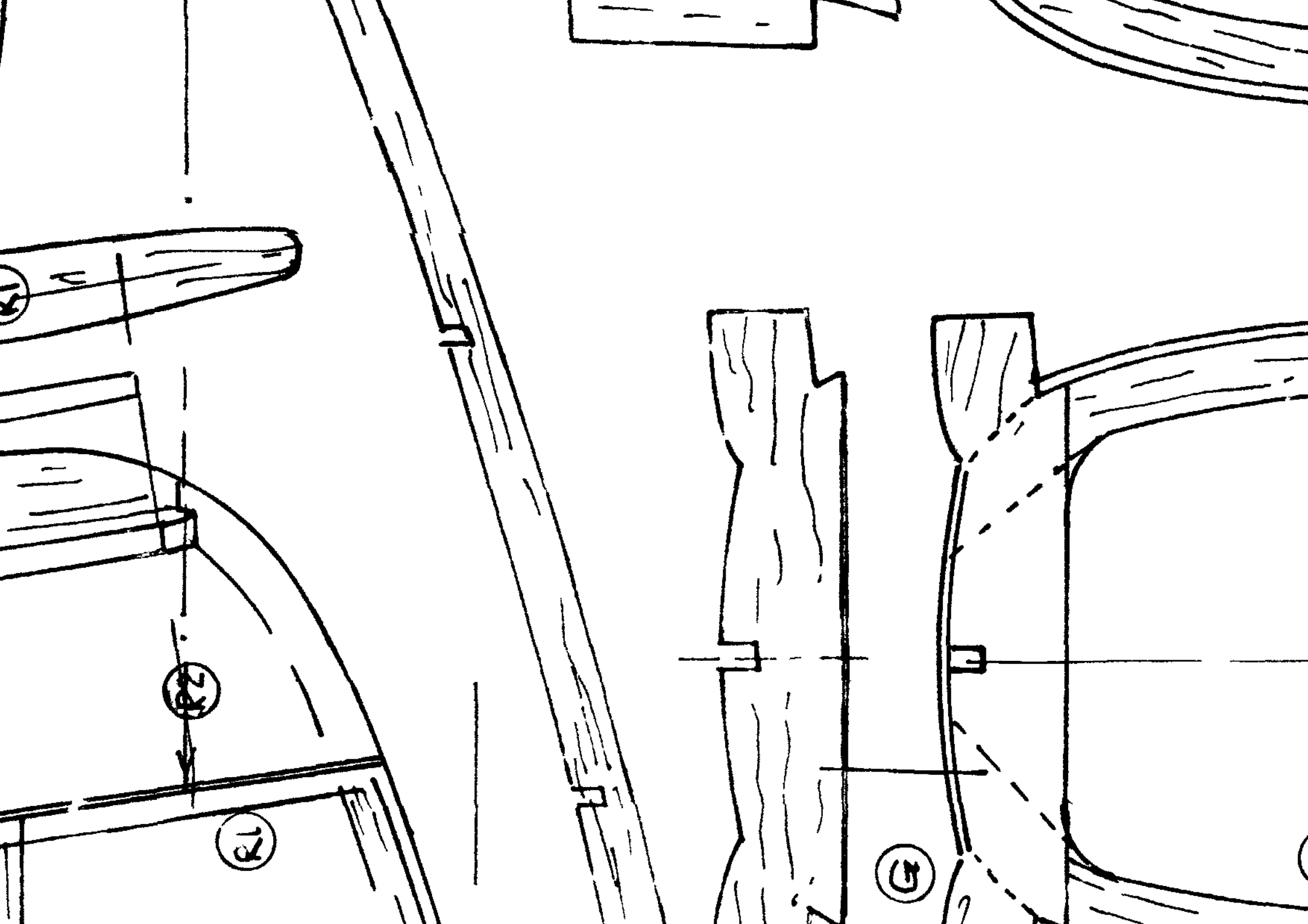

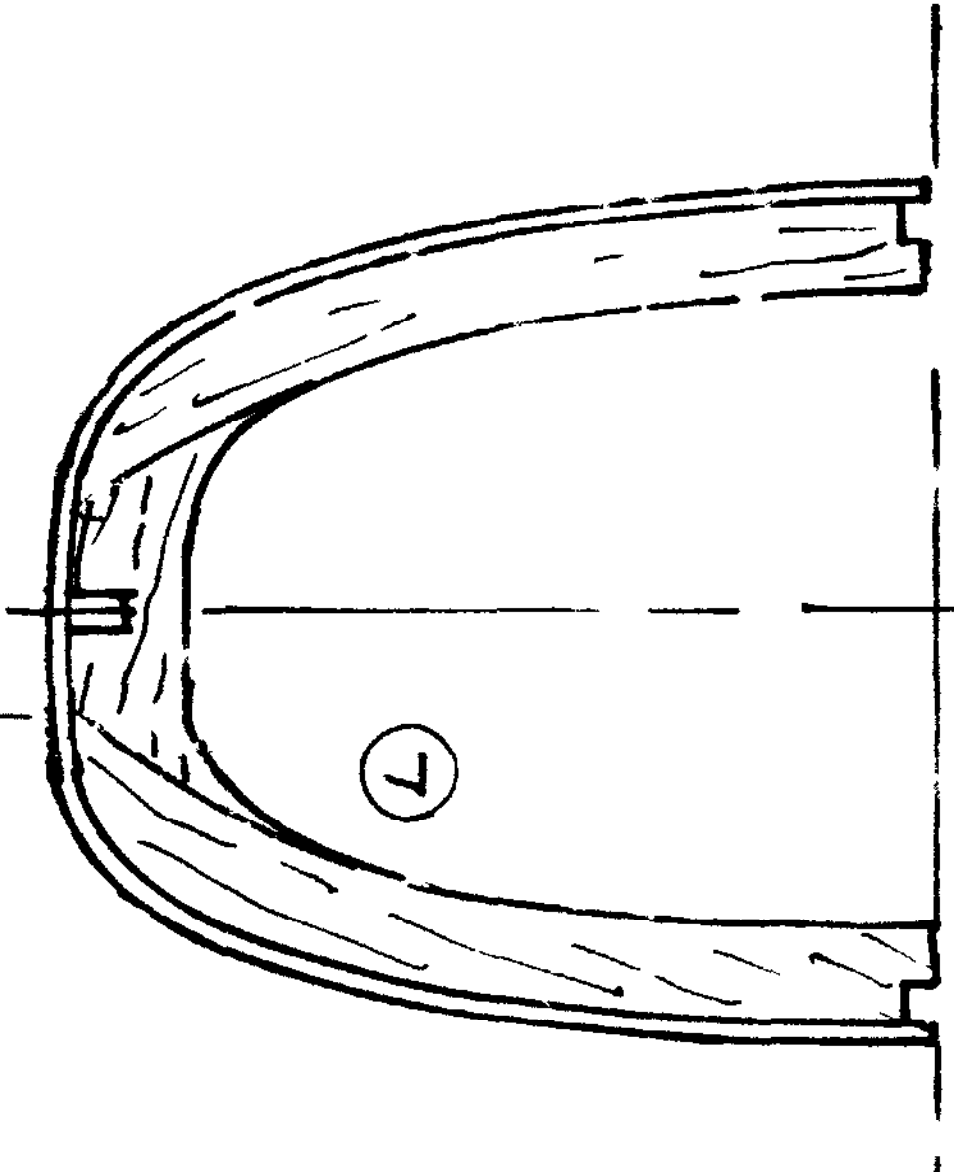
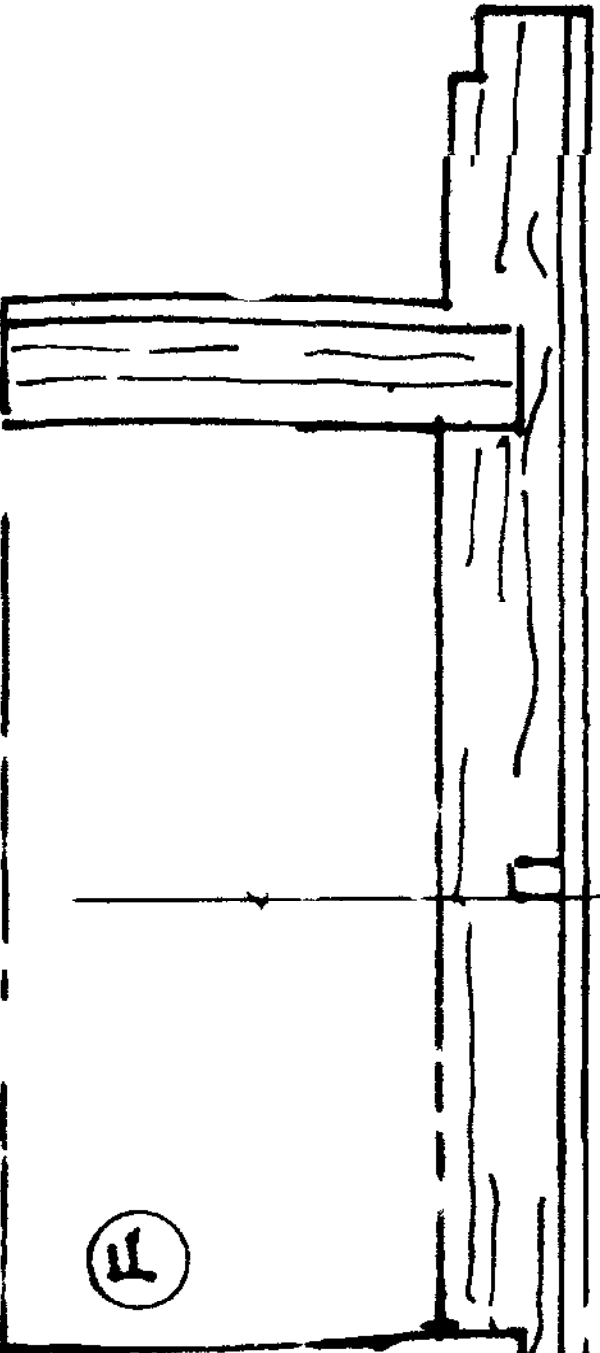
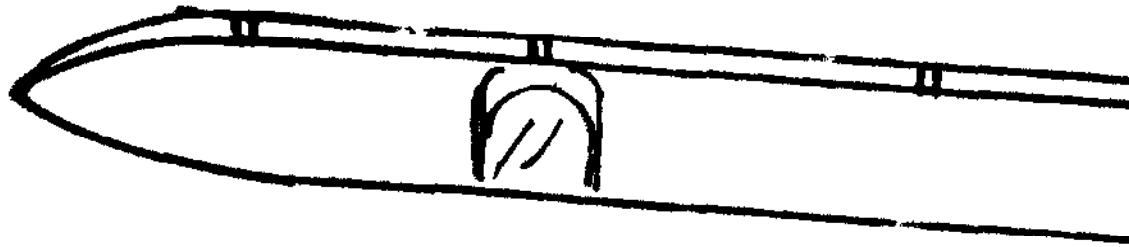
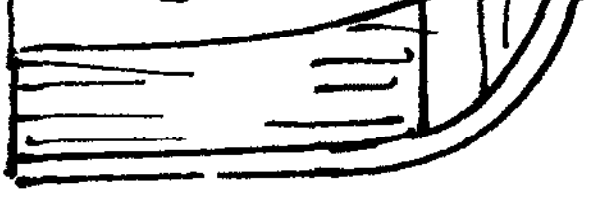
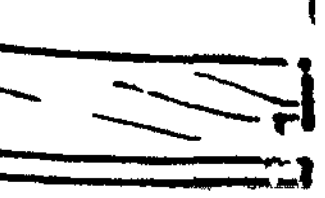

4.

F

7

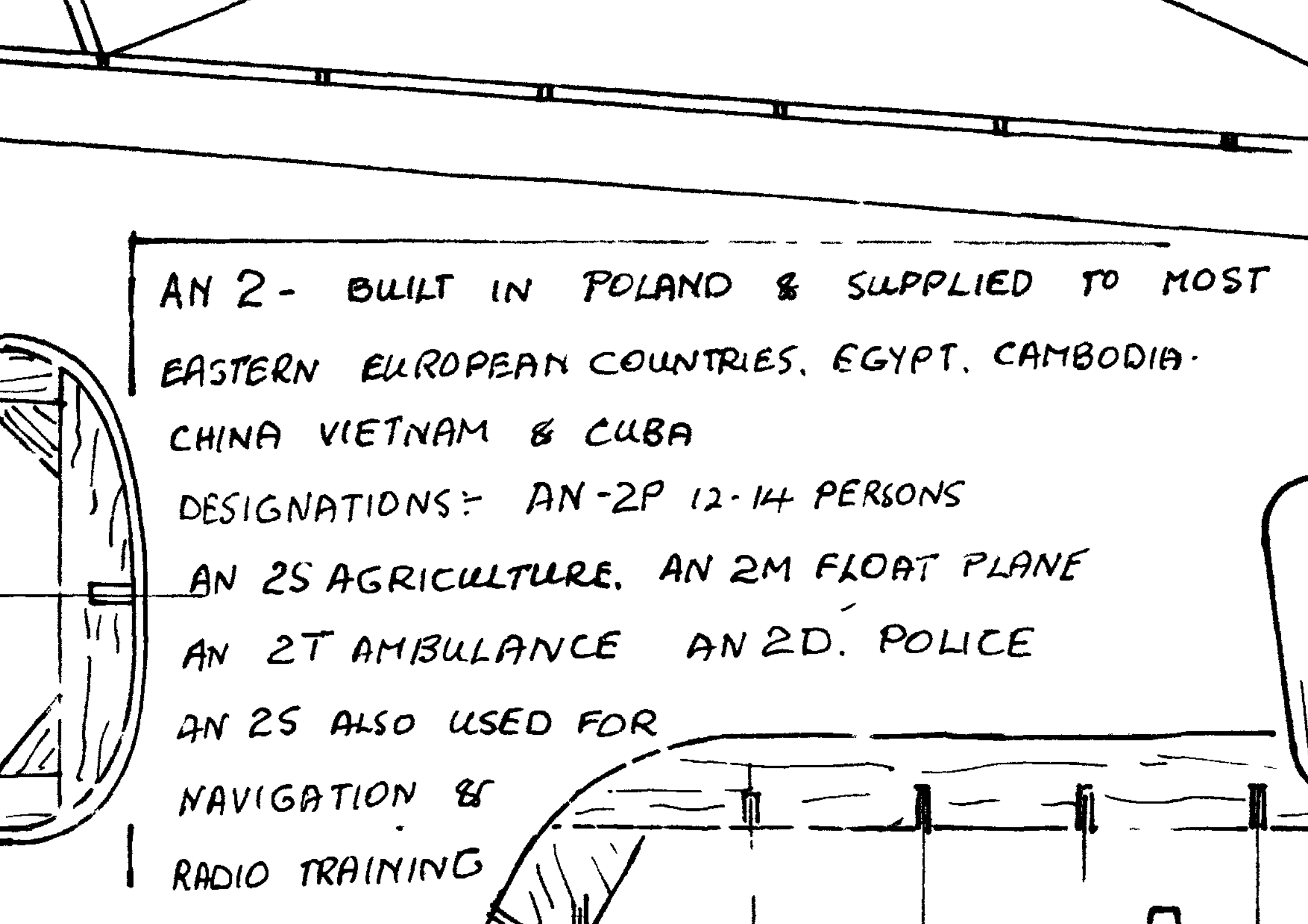

AN 2 - BUILT IN POLAND & SUPPLIED TO MOST
EASTERN EUROPEAN COUNTRIES, EGYPT, CAMBODIA.
CHINA VIETNAM & CUBA

DESIGNATIONS: AN-2P 12-14 PERSONS

AN 2S AGRICULTURE, AN 2M FLOAT PLANE

AN 2T AMBULANCE AN 2D. POLICE

AN 2S ALSO USED FOR

NAVIGATION &

RADIO TRAINING

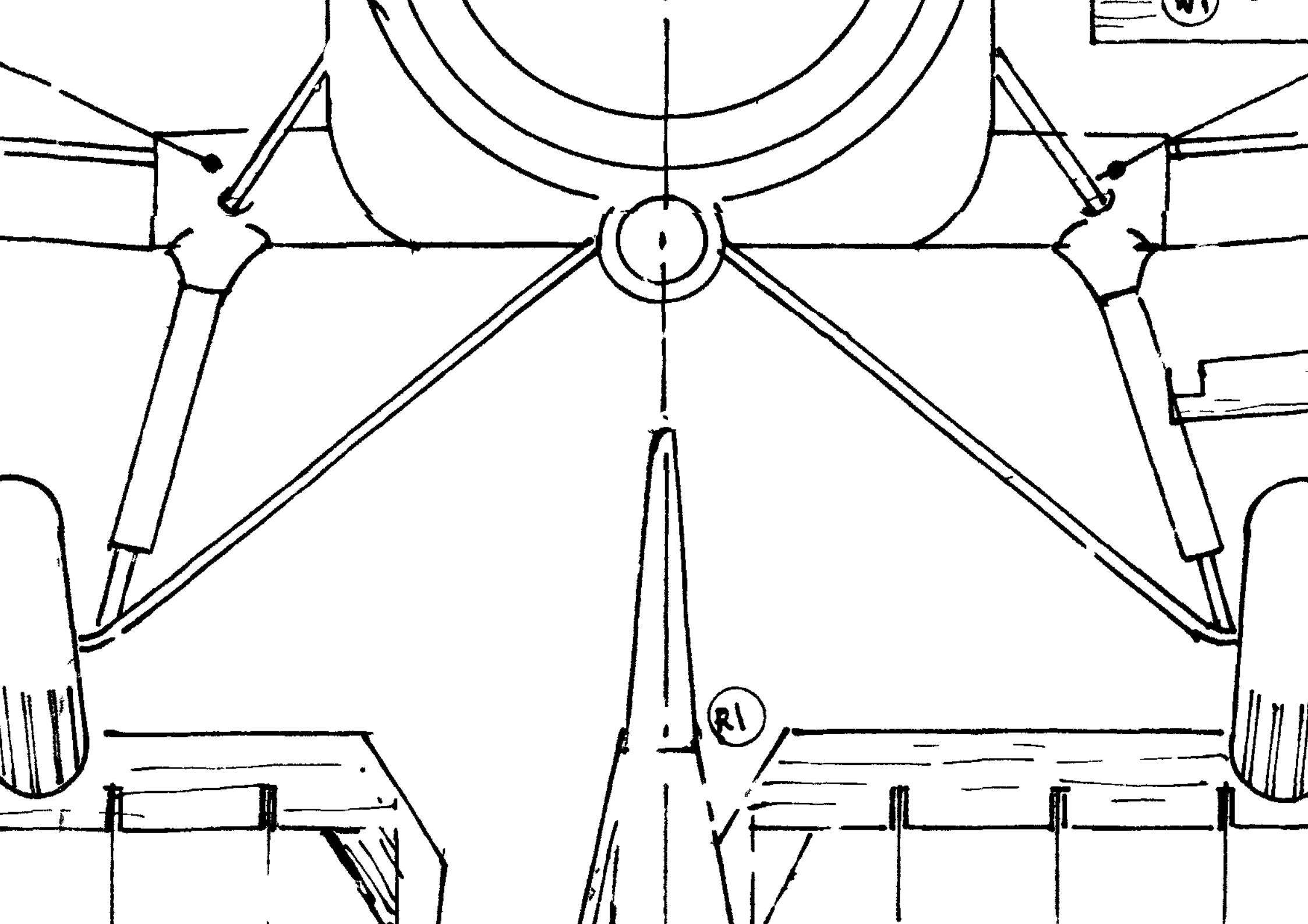

TAXIING

LOWER REAR SPAR 20FF

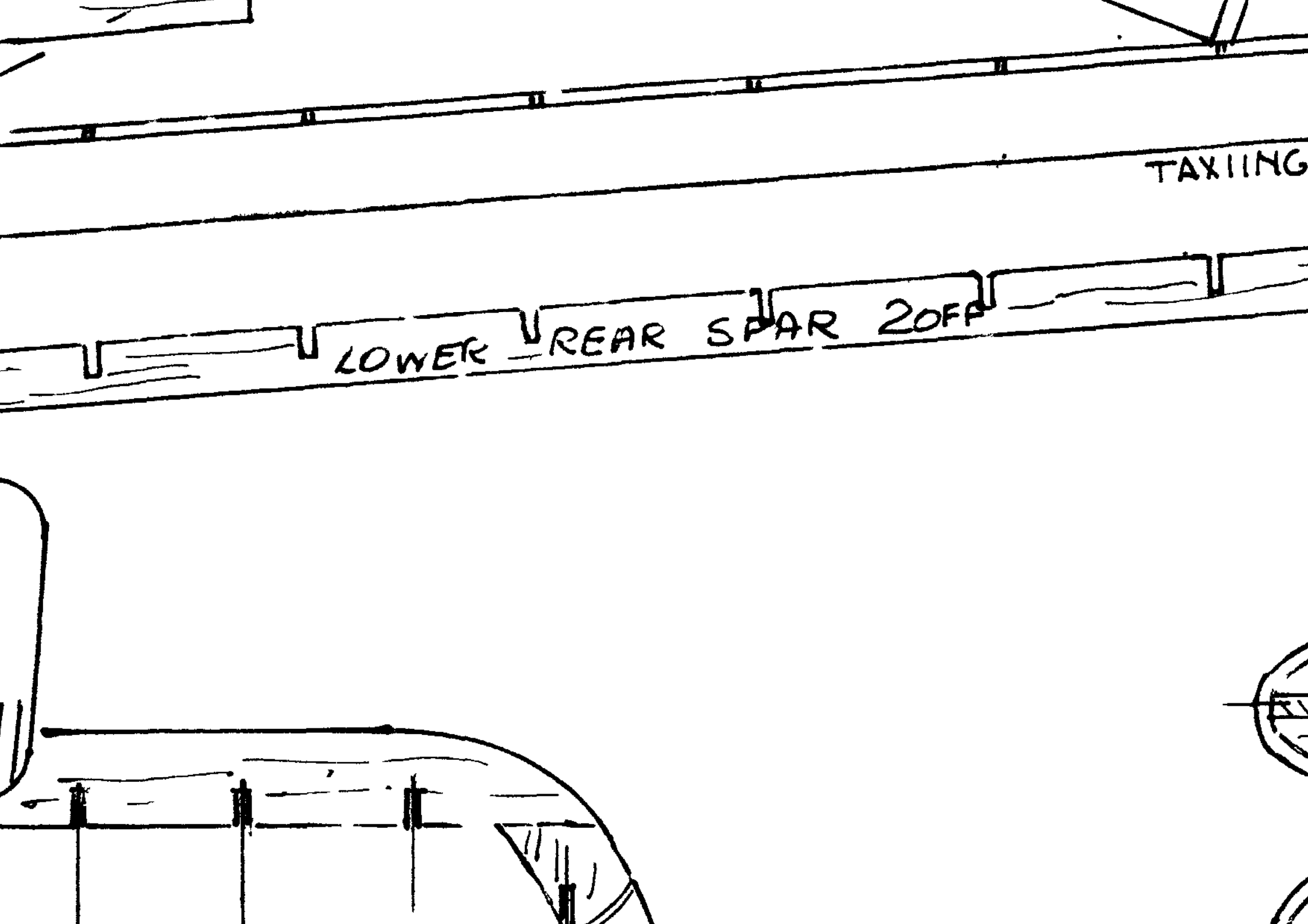

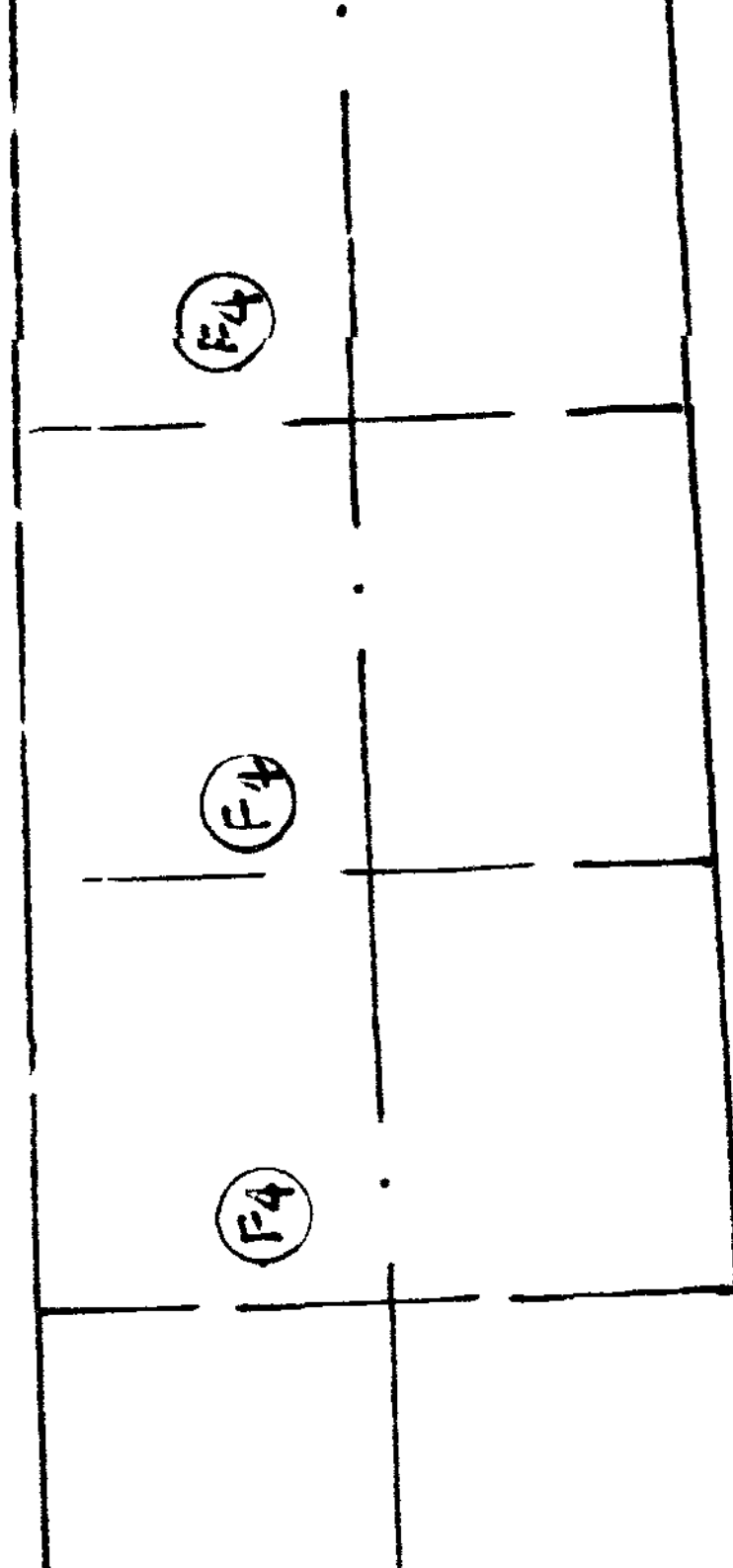
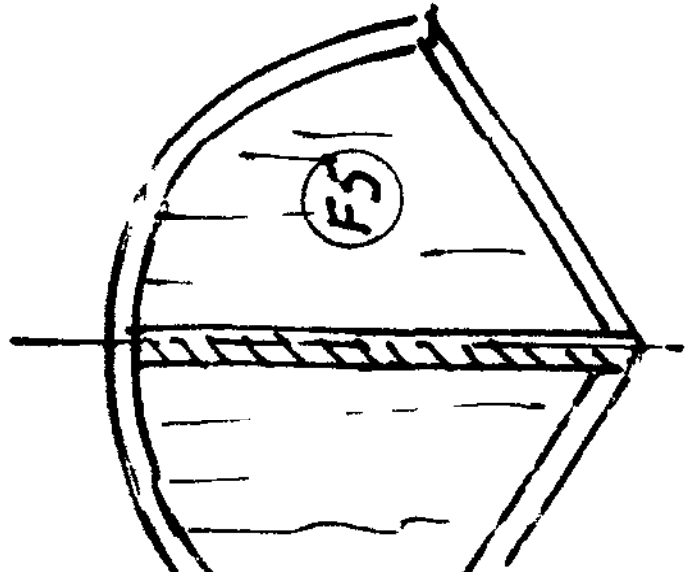
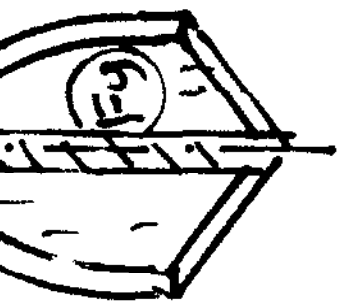
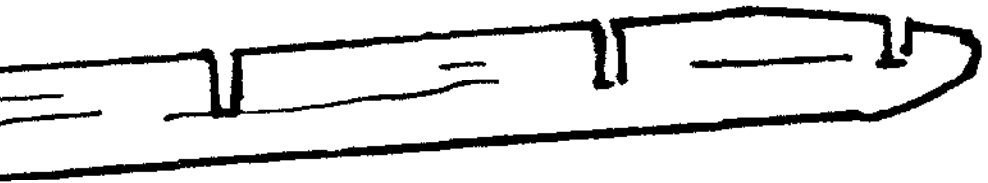
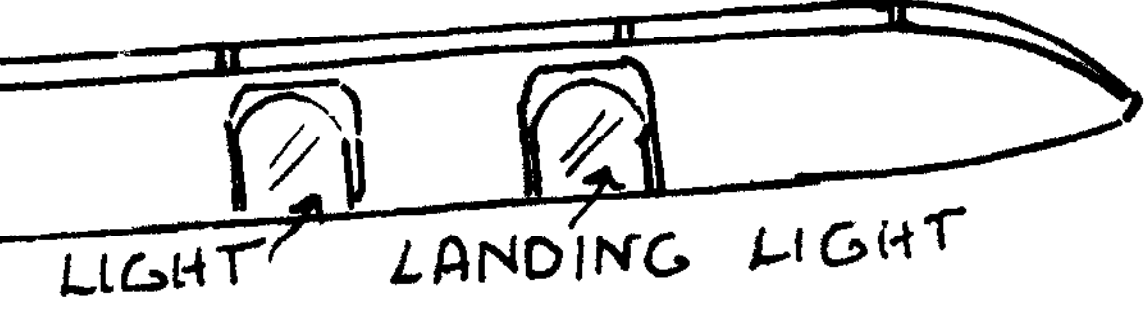

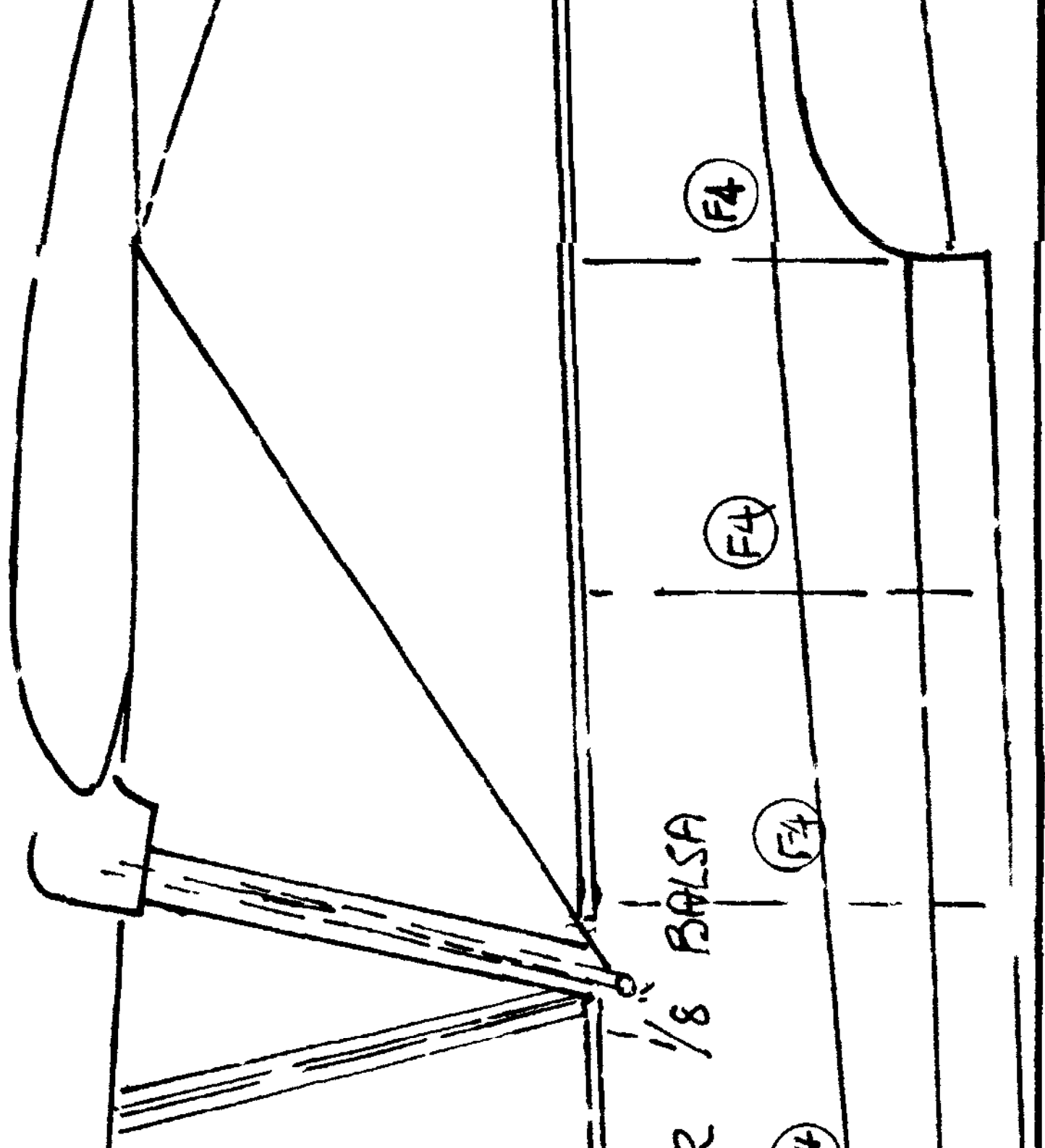

F4

F4

F4

F4

1/8 BALS

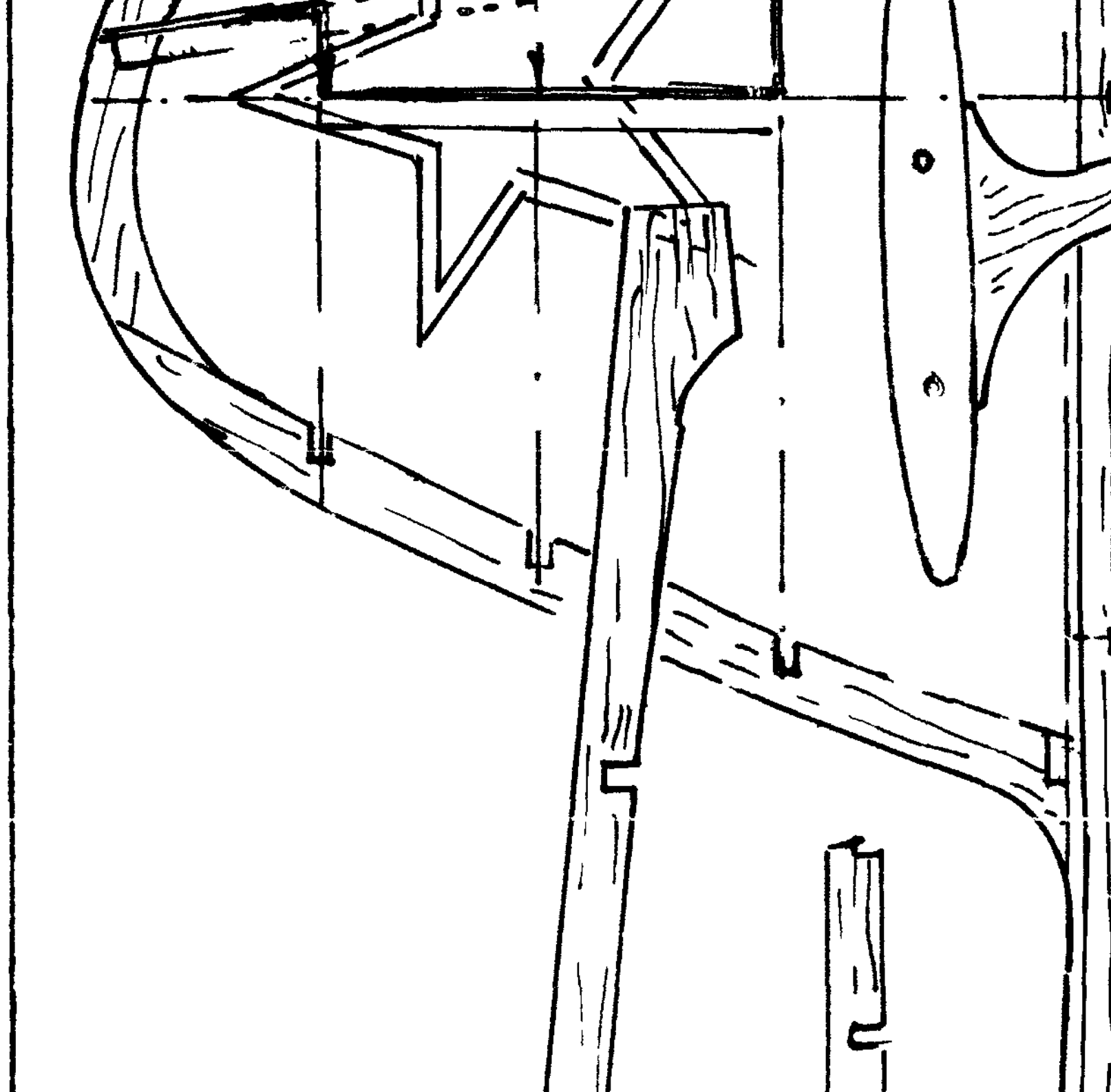

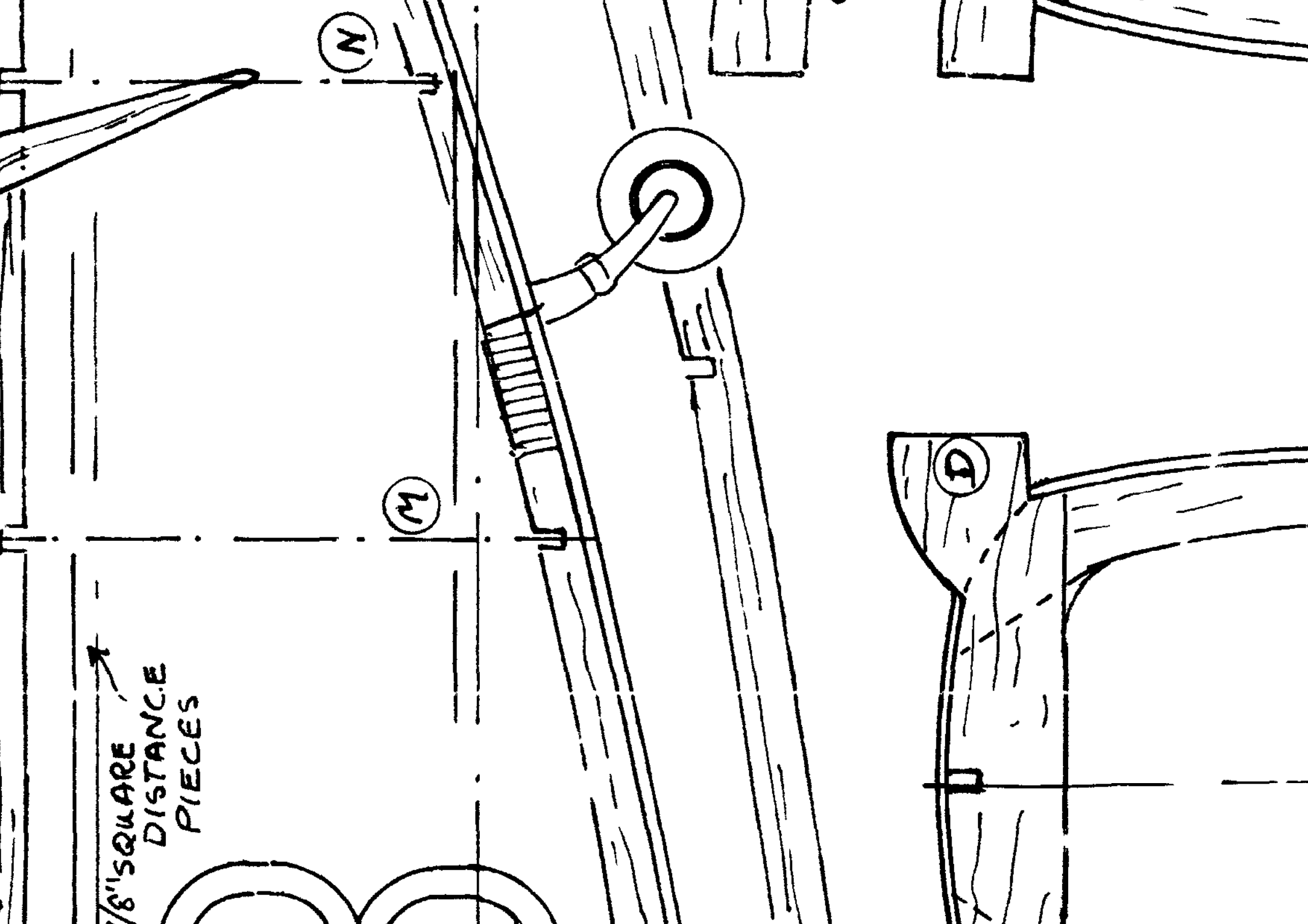

N

M

P

1/8" SQUARE
DISTANCE
PIECES

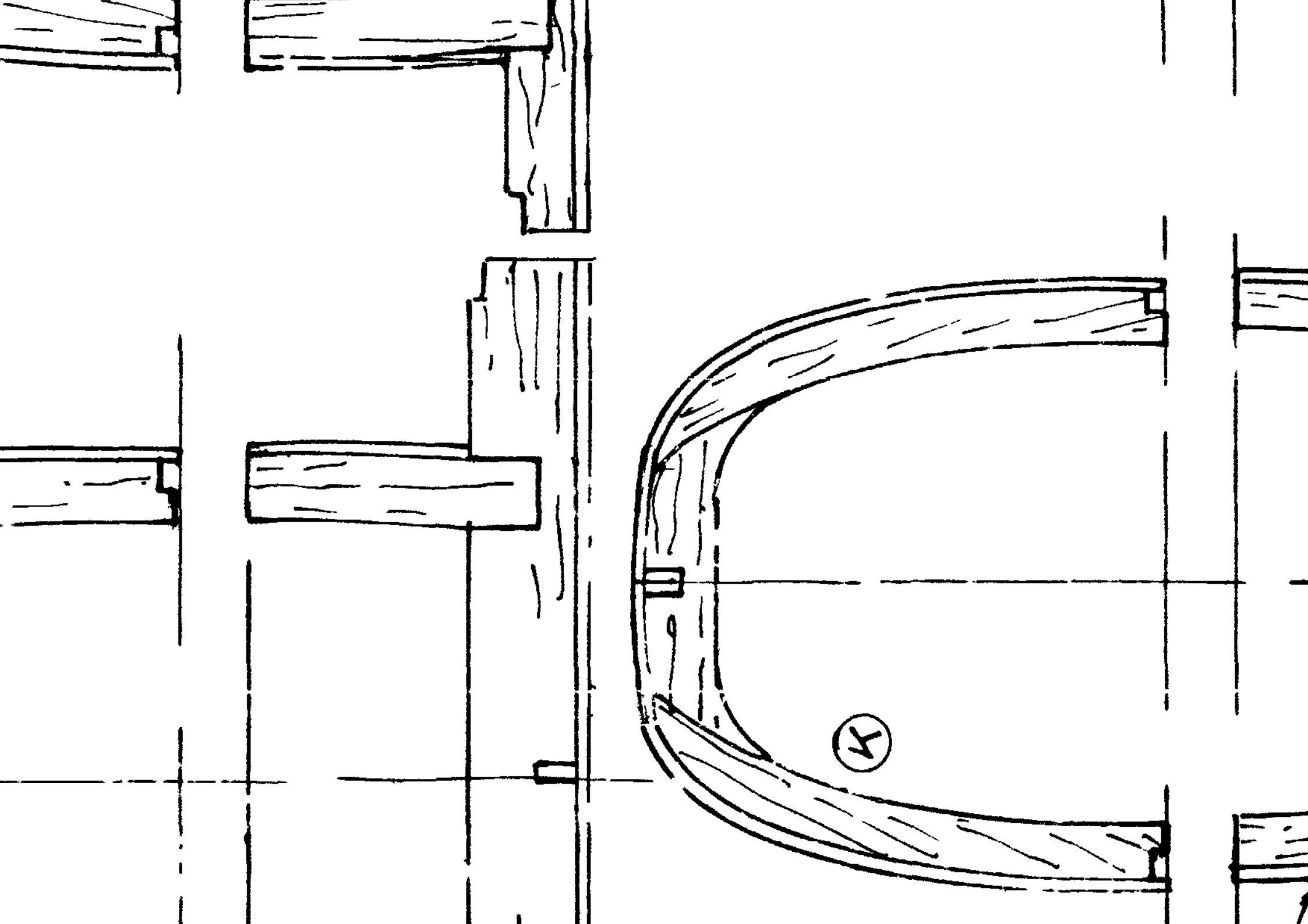

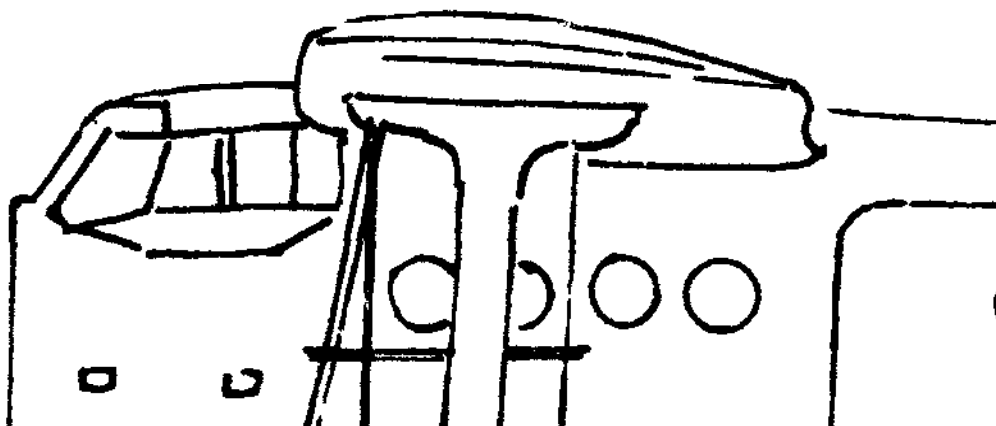
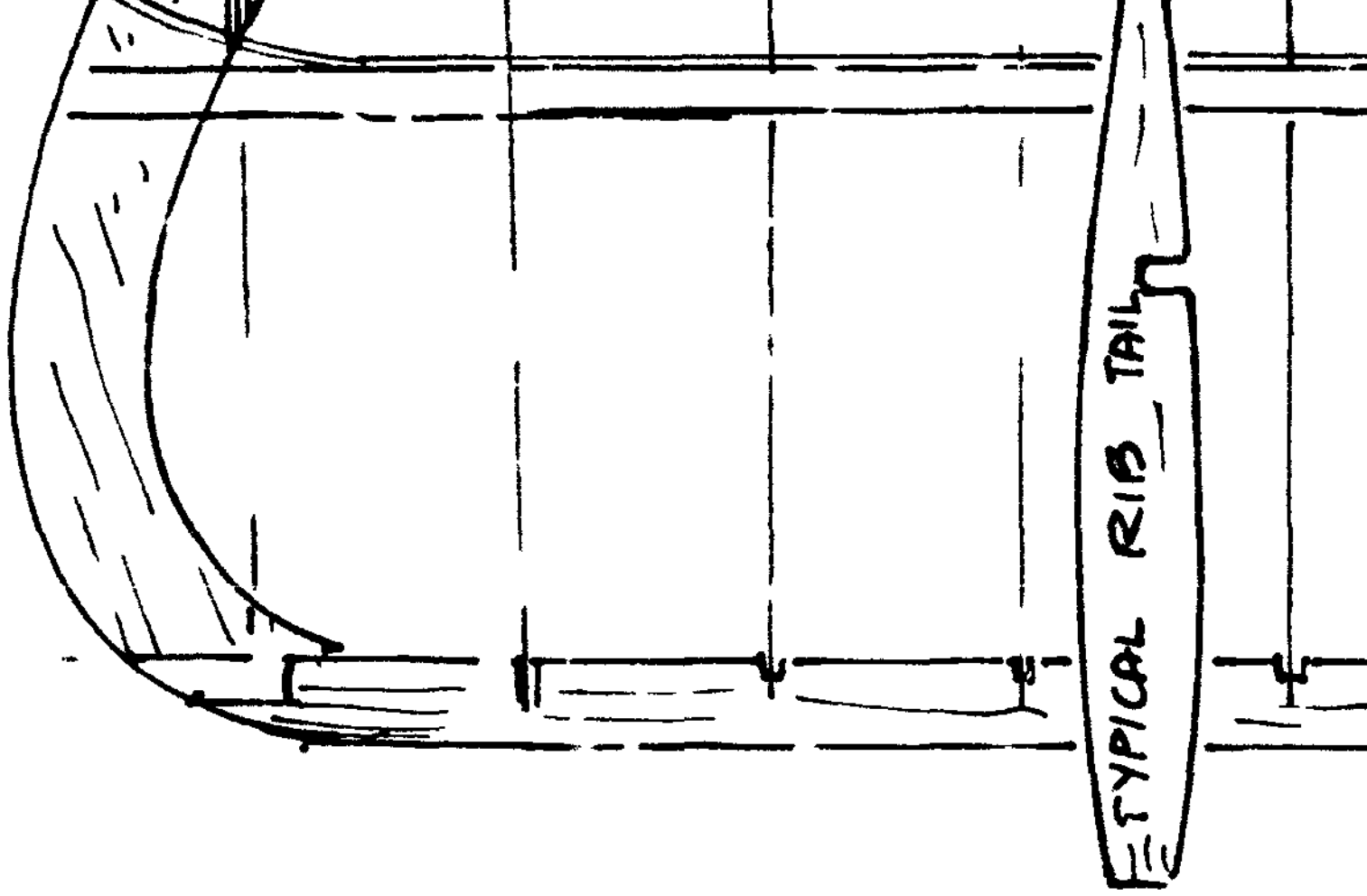
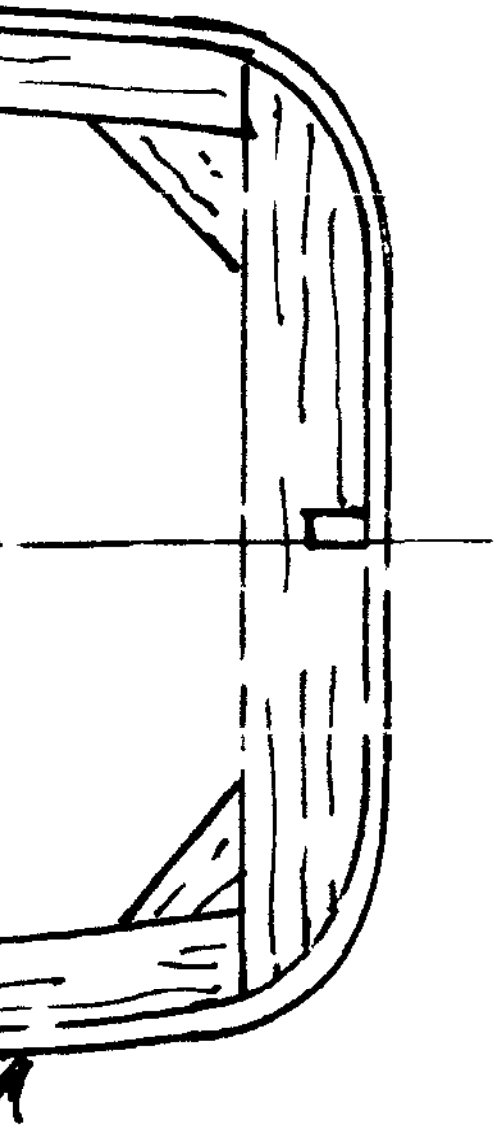

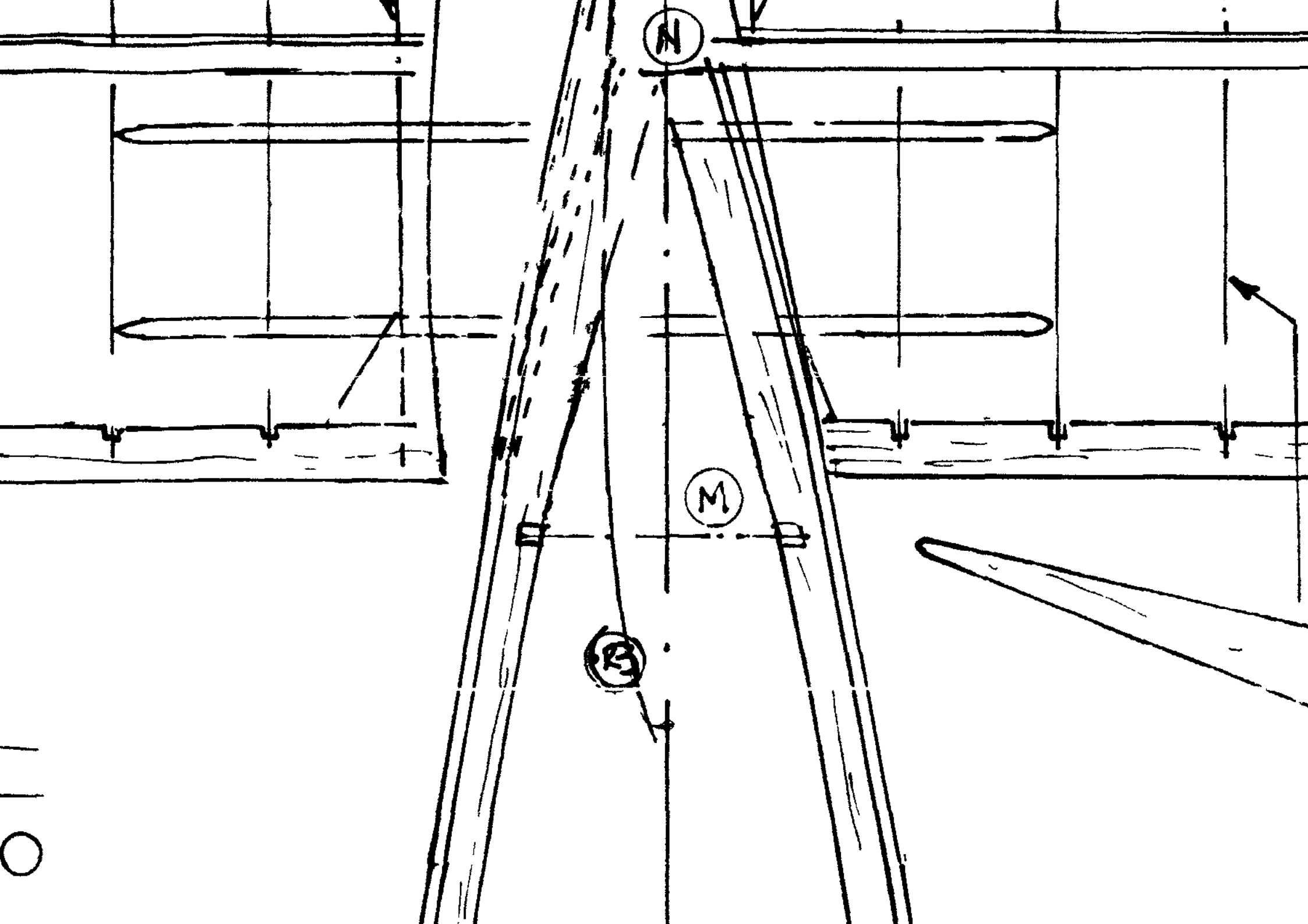

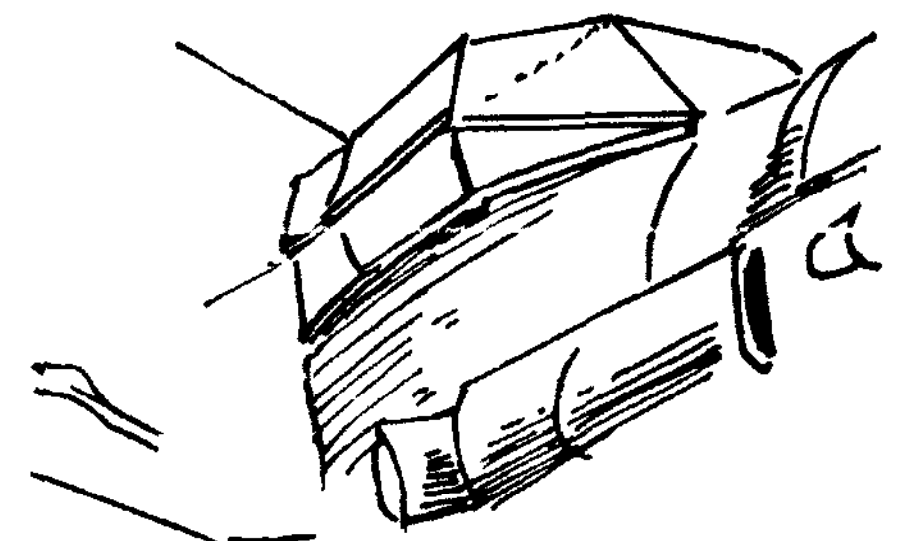
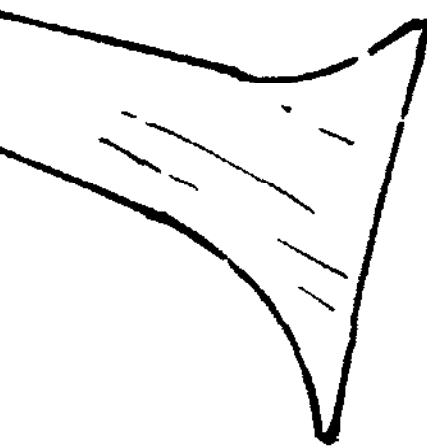
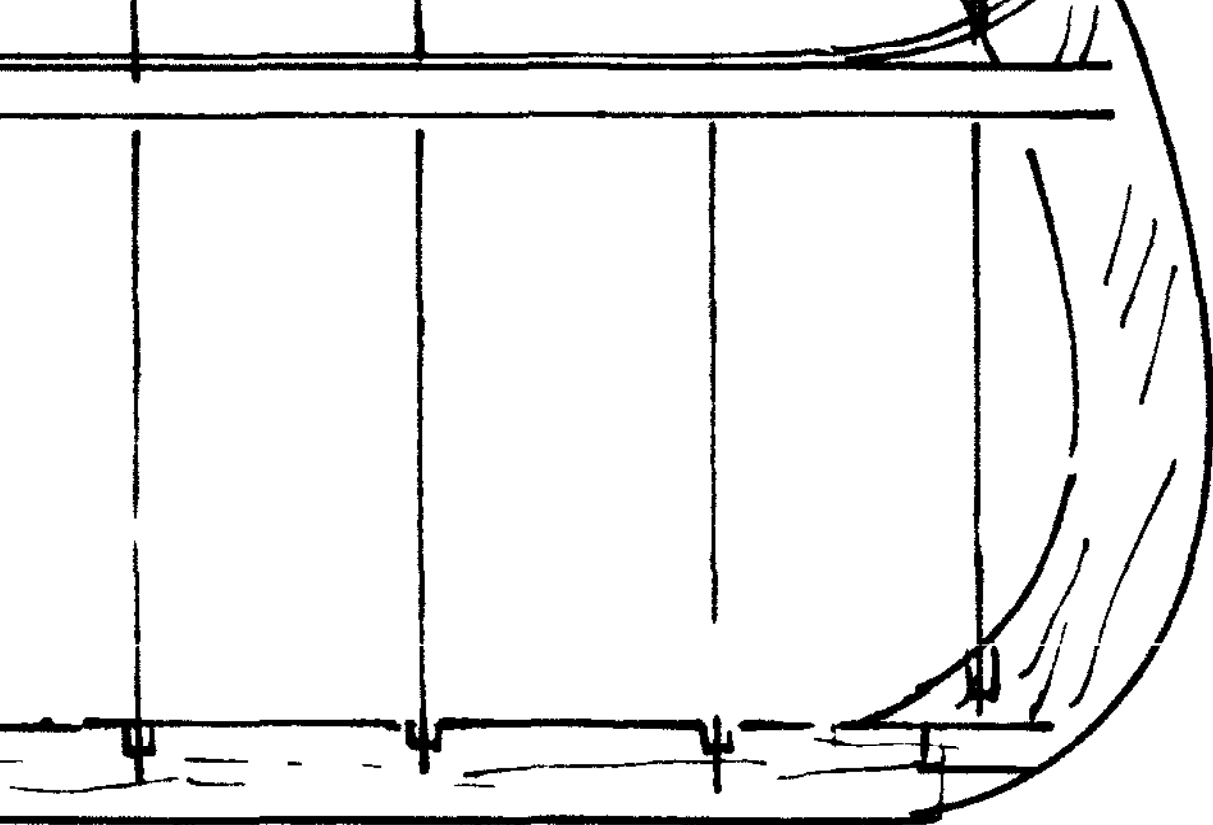

VIEW SHOWING CANOPY OVERHANG



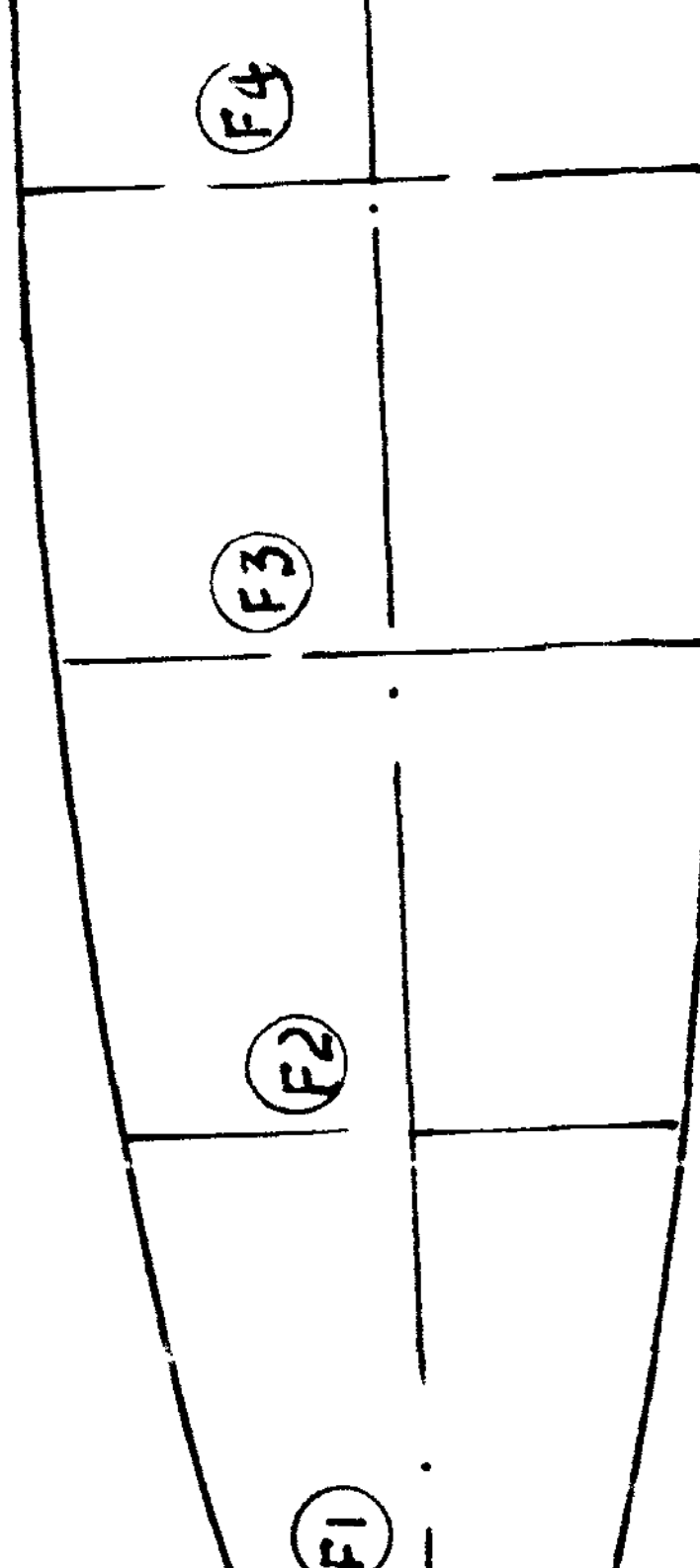
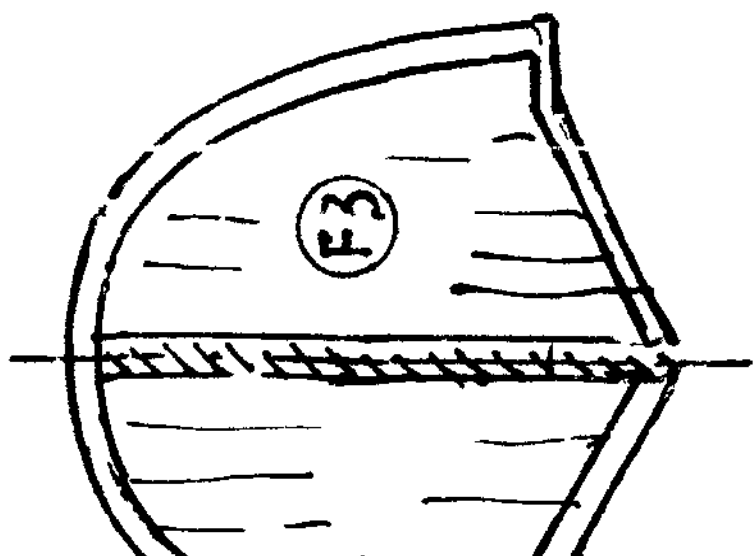
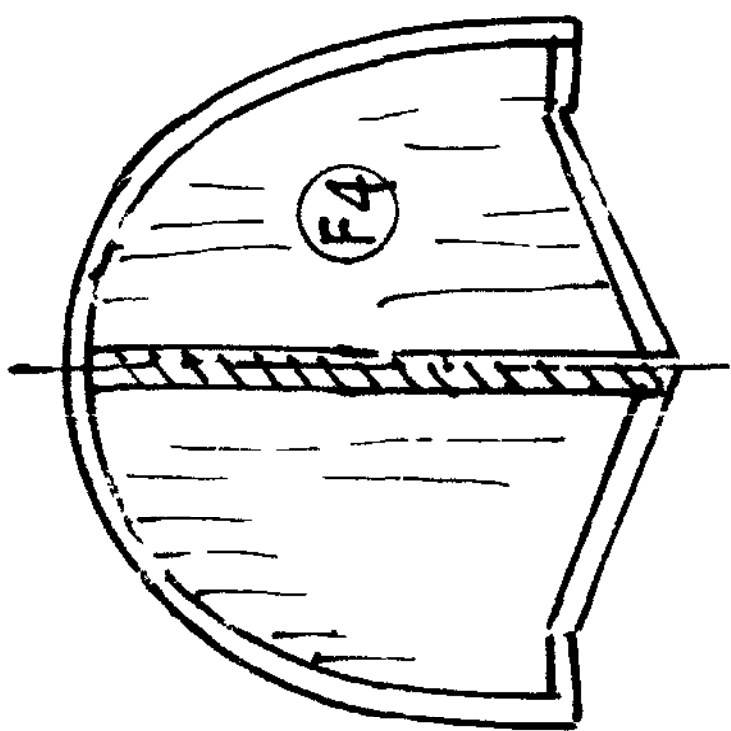
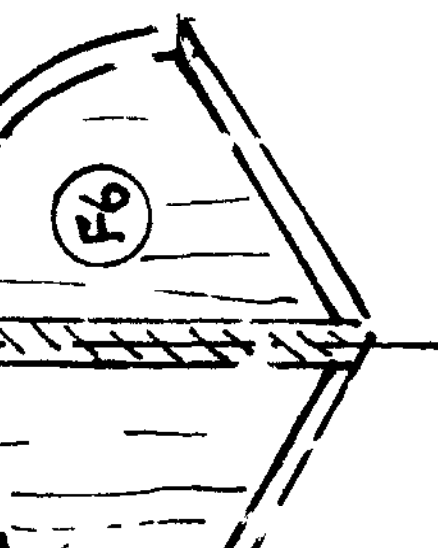
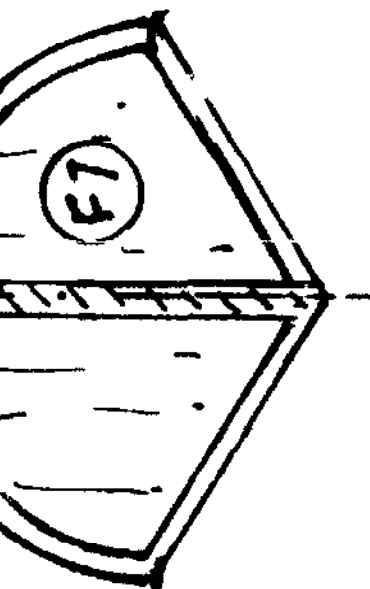
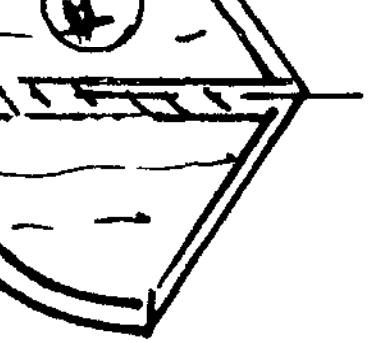

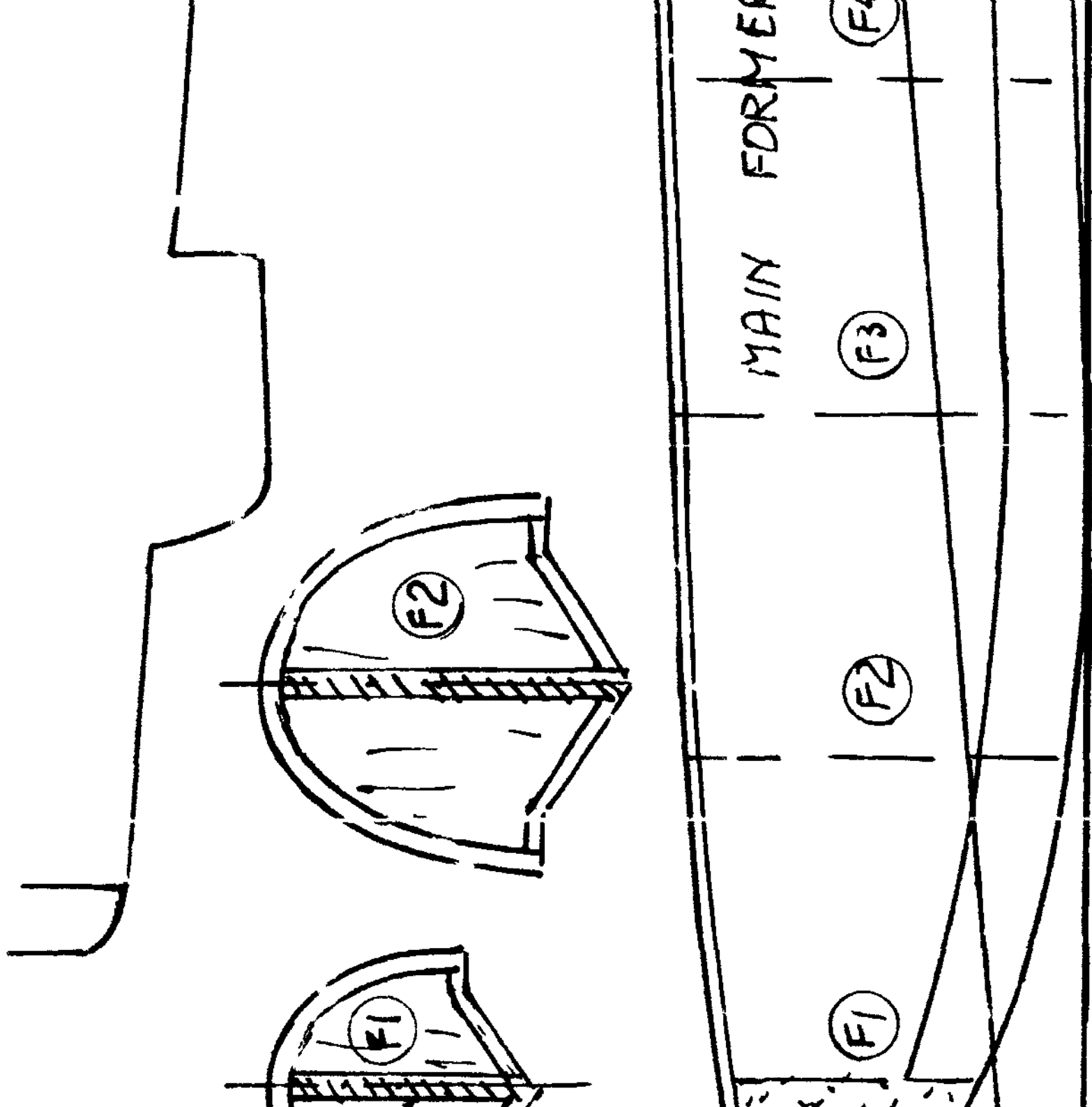

20FF Π

Π 10FF -

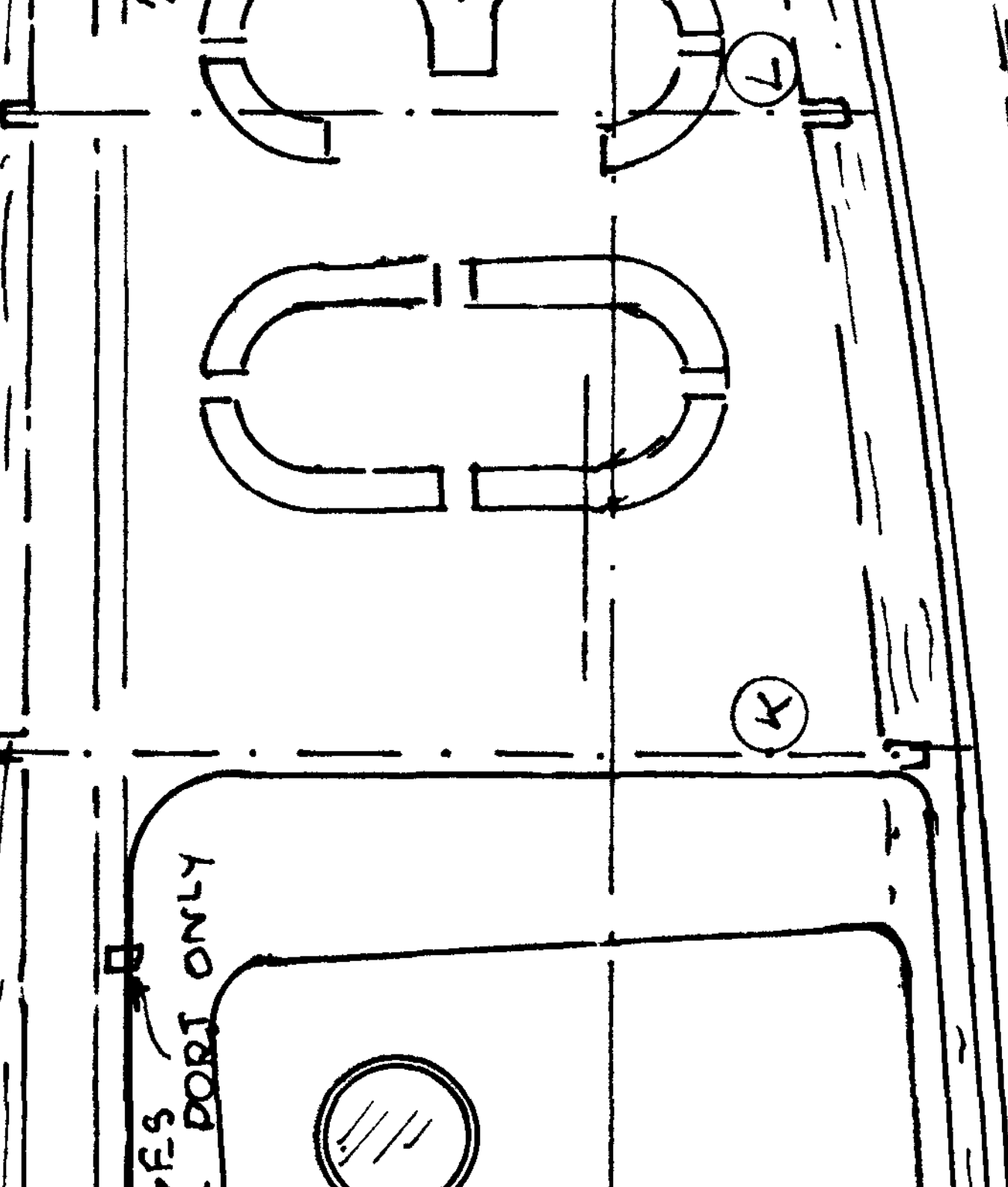

THESE CENTRE S
CAN BE MADE OP

STRINGER LOFF

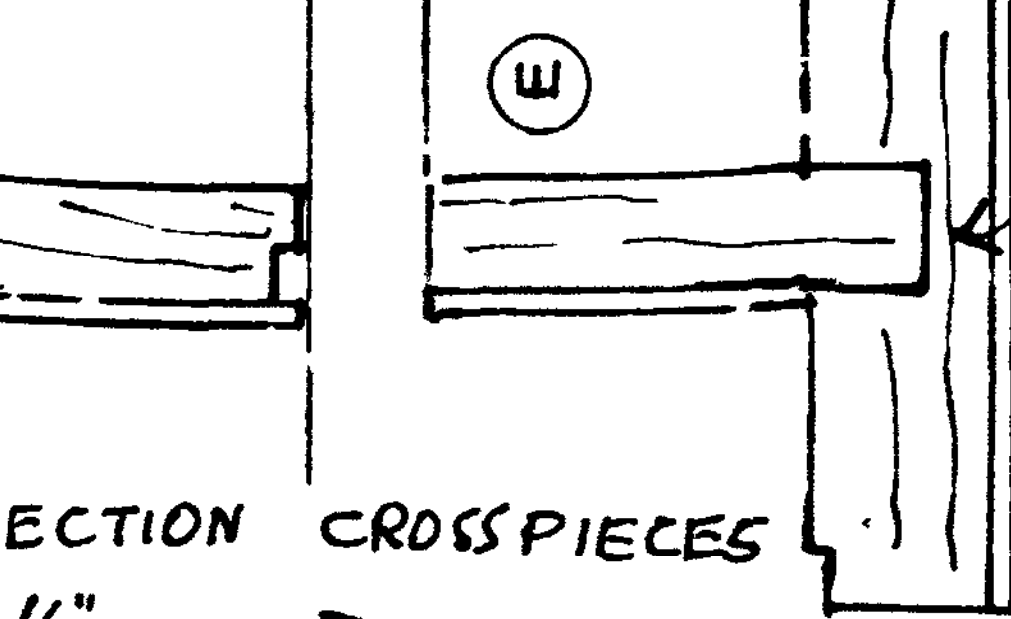

FLUSH FITTING

NOTE: ALL FORMERS SHOW

SECTION CROSSPIECES
 $\frac{1}{8}$ " HARD 3 PLY TO ADVANTAGE

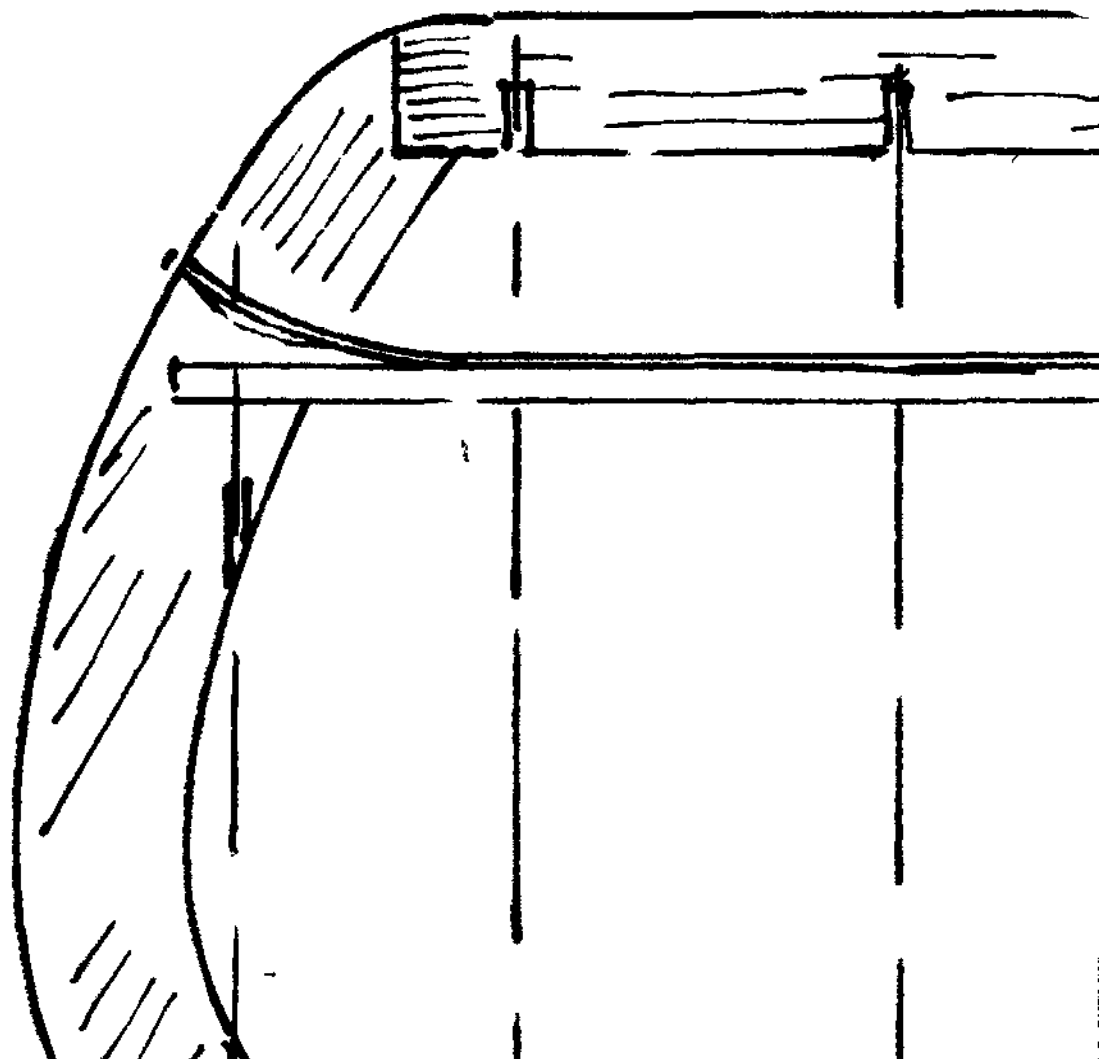
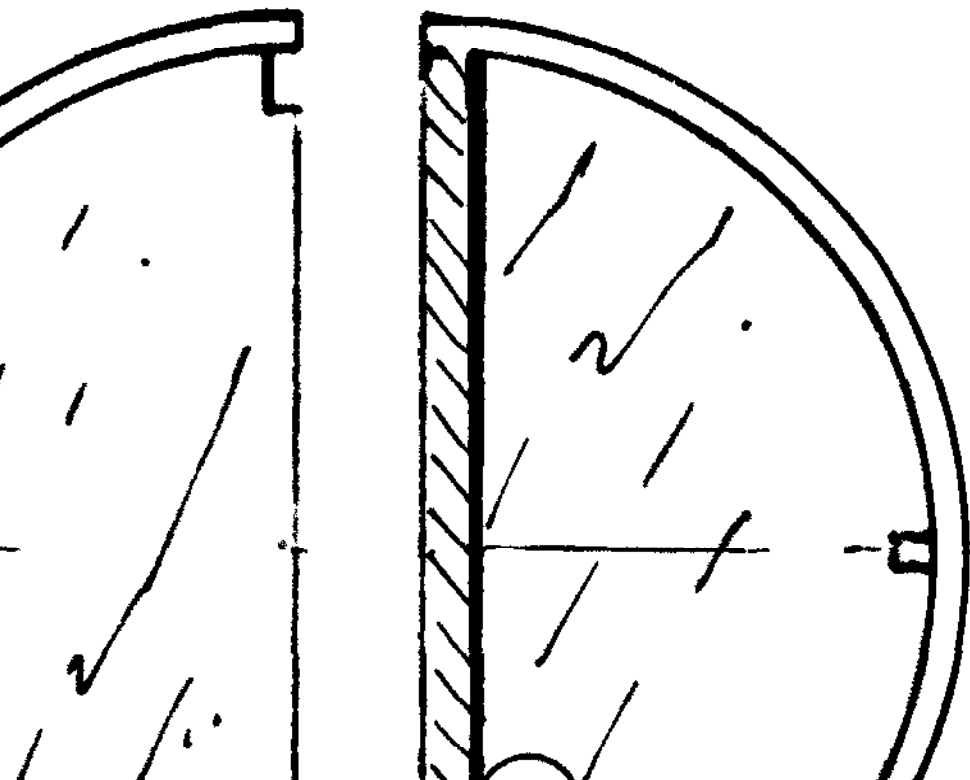

1/16" PLANKING



VIEW SHOWING FLYING

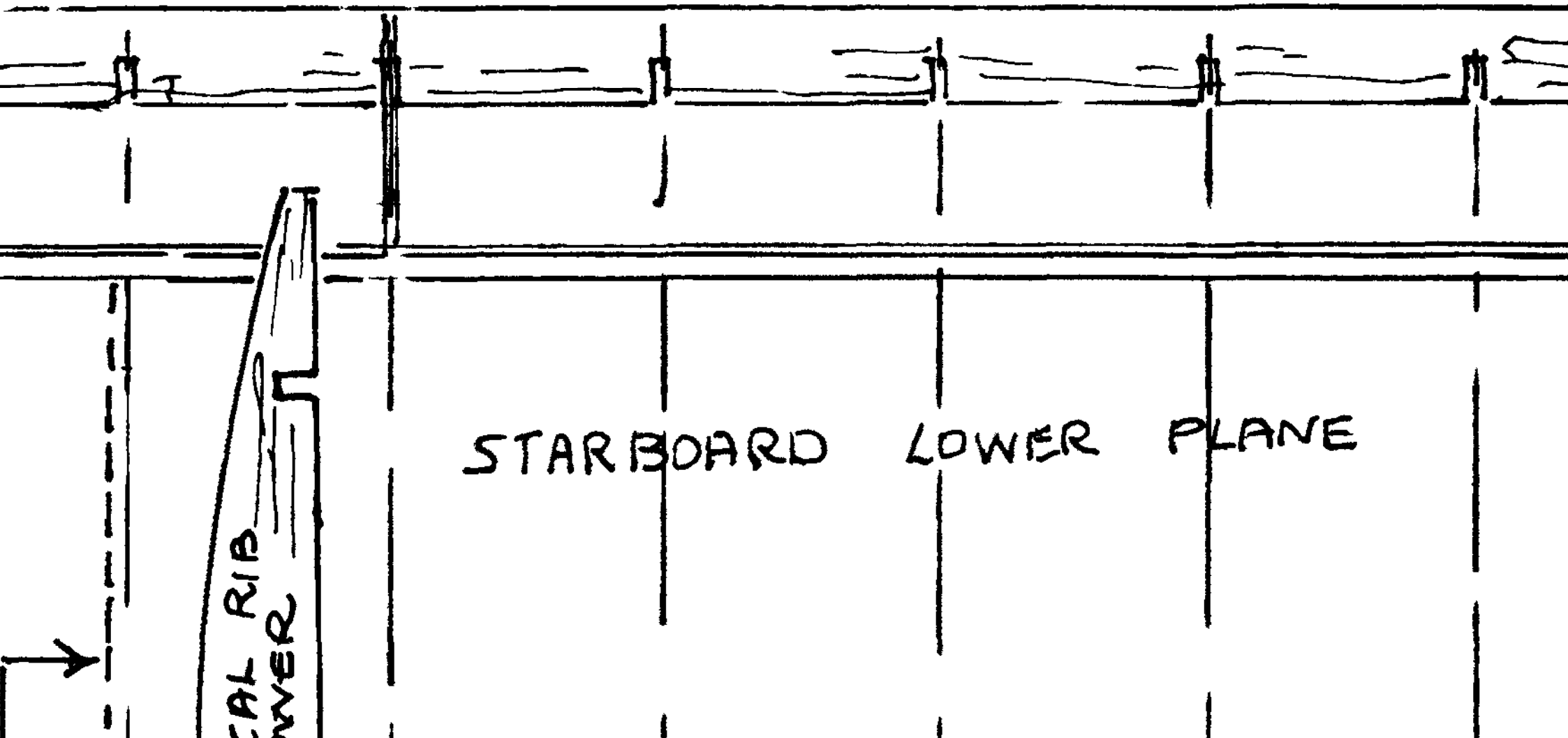

WIRES

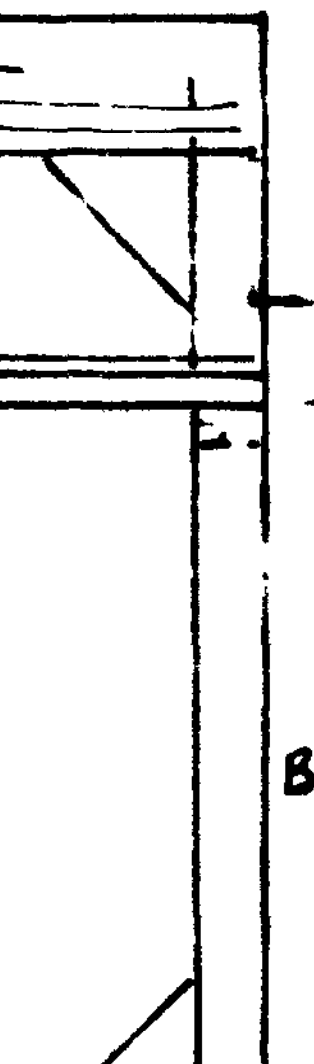

W2
↑
FITS
BETWEEN
↓

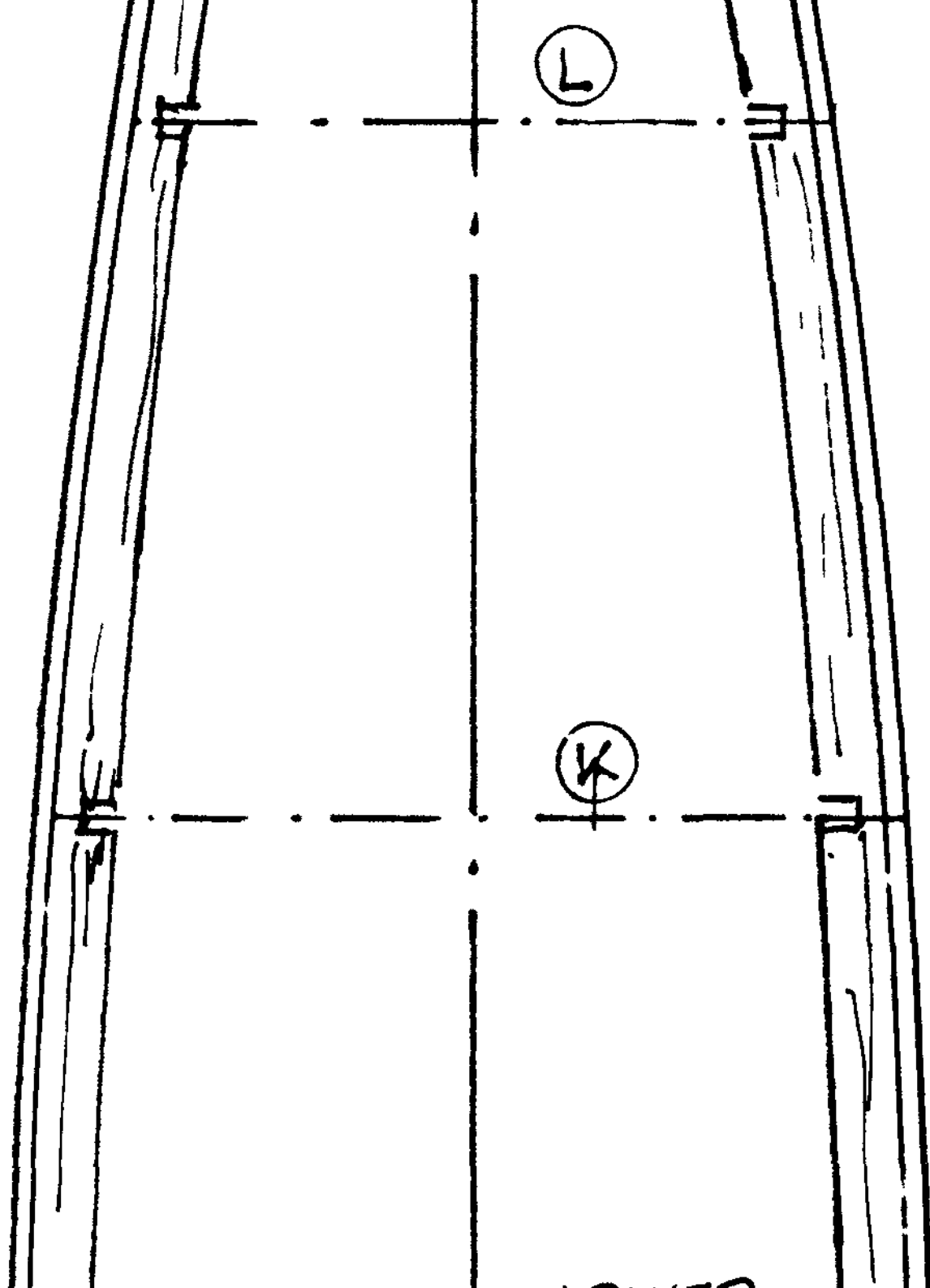

Ⓛ

Ⓚ

CAN

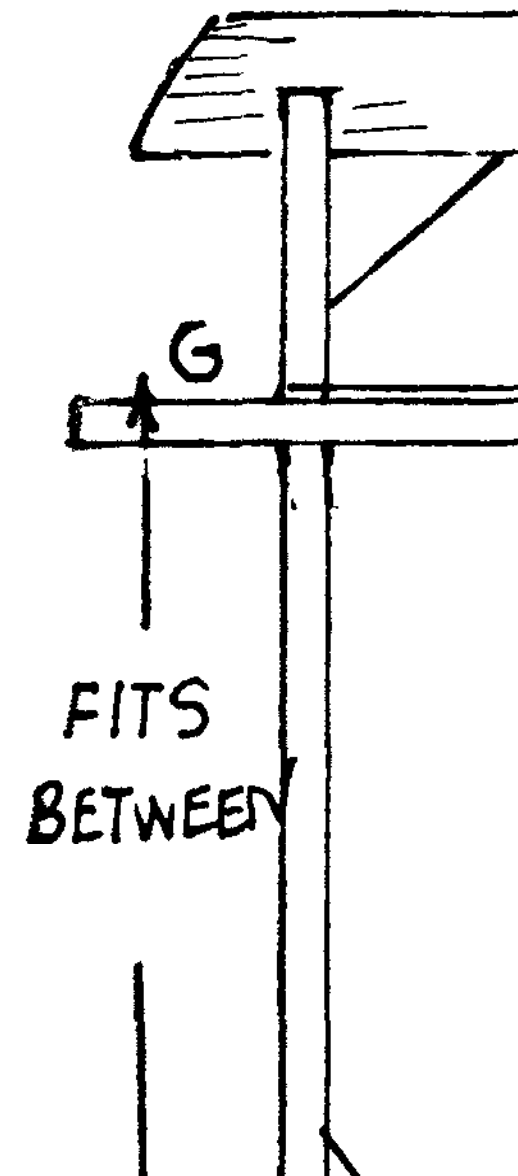

G
↑
FITS
BETWEEN
↓

ALSO EXHAUST.

COPY MADE WITH 18G WIRE SOLDERED & CLEAR PLASTIC

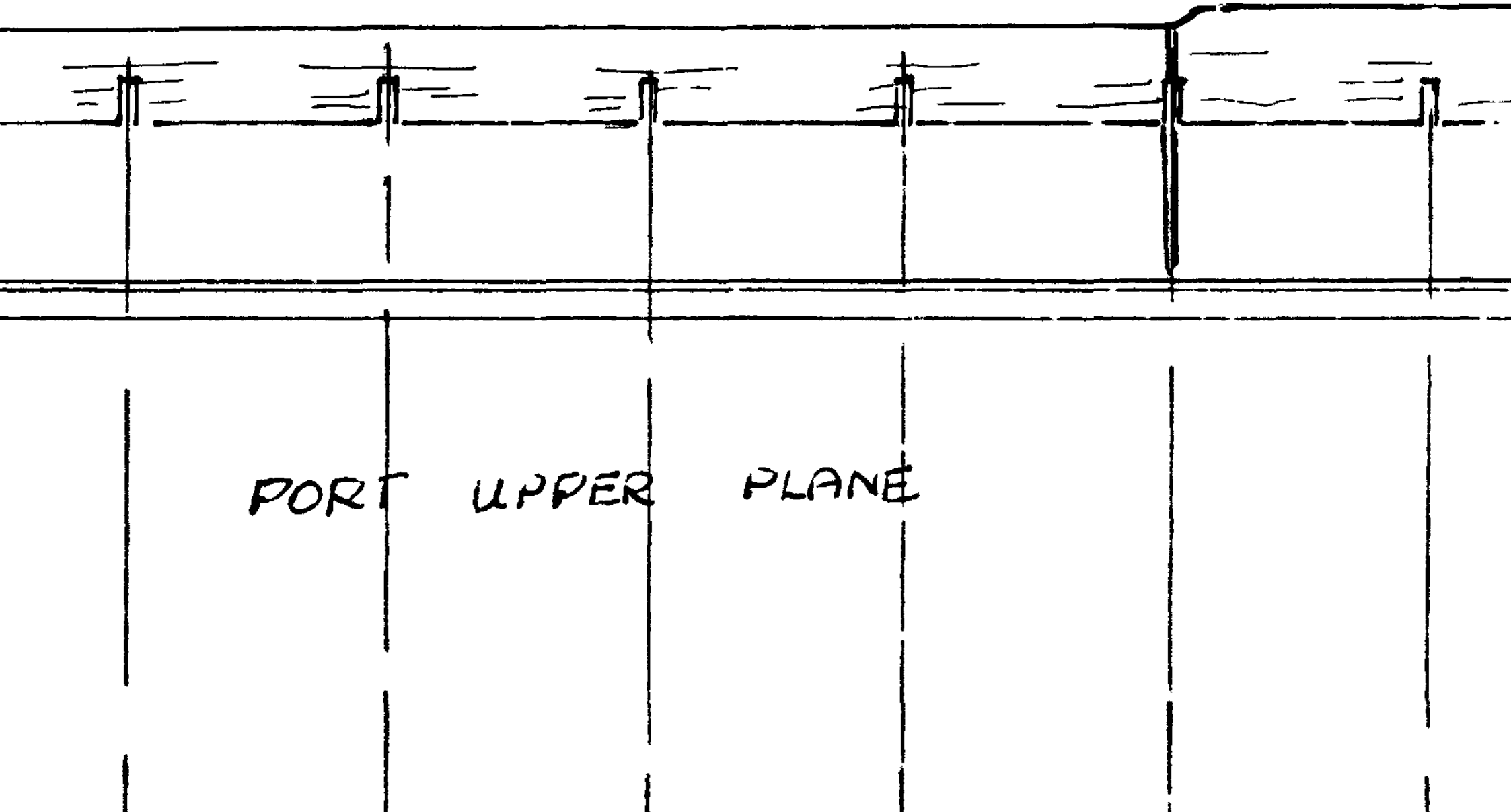



INSERTS

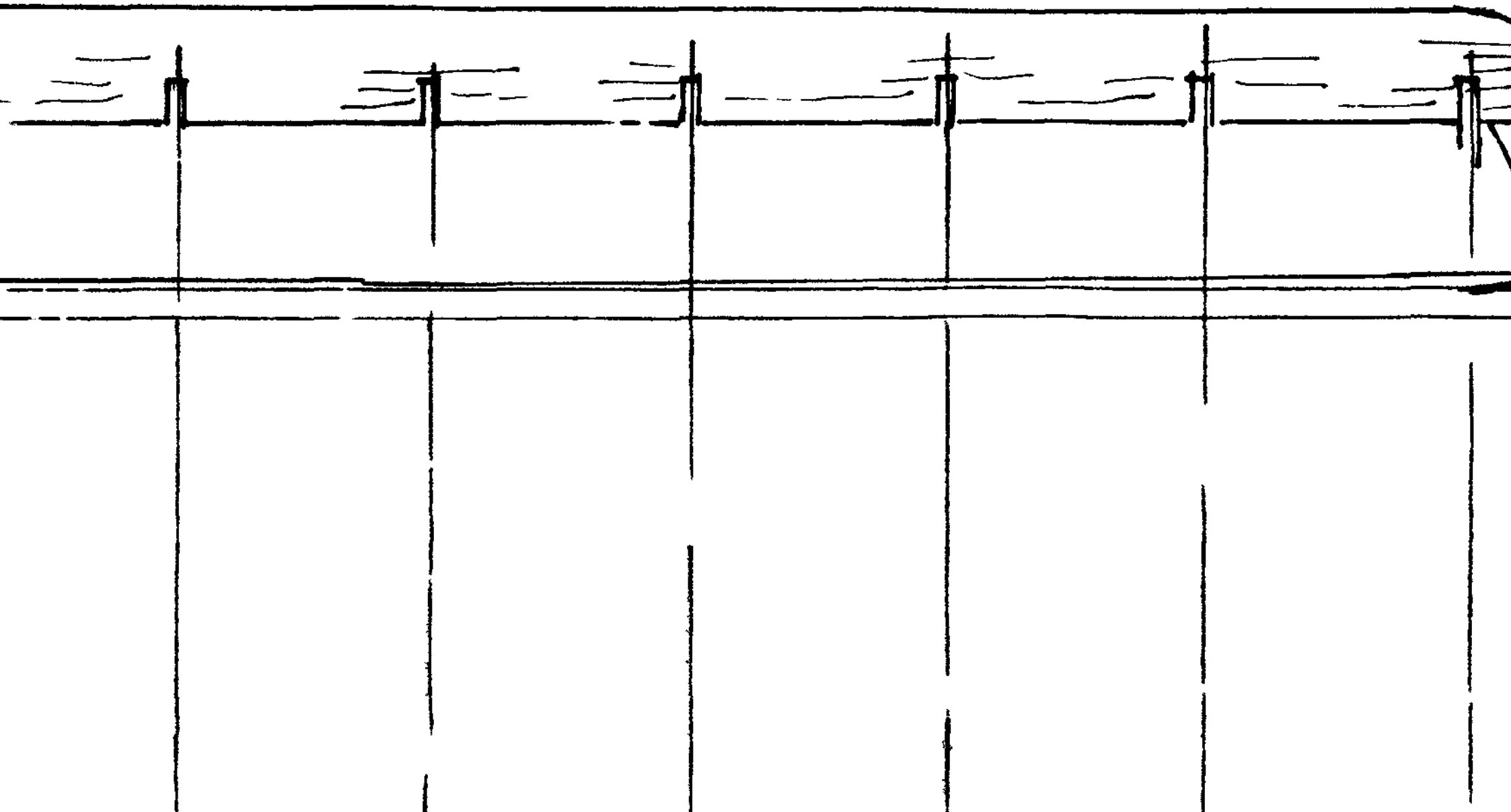

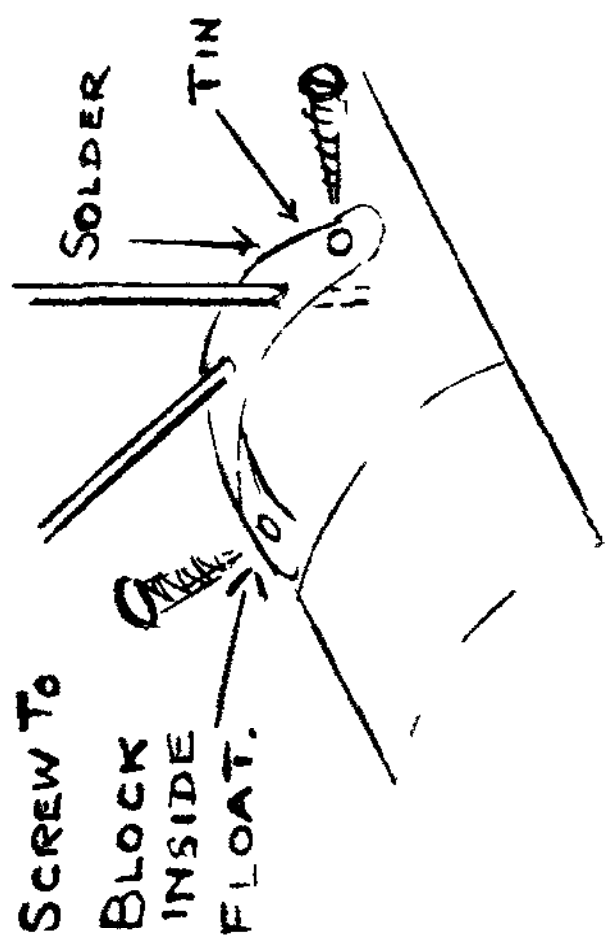
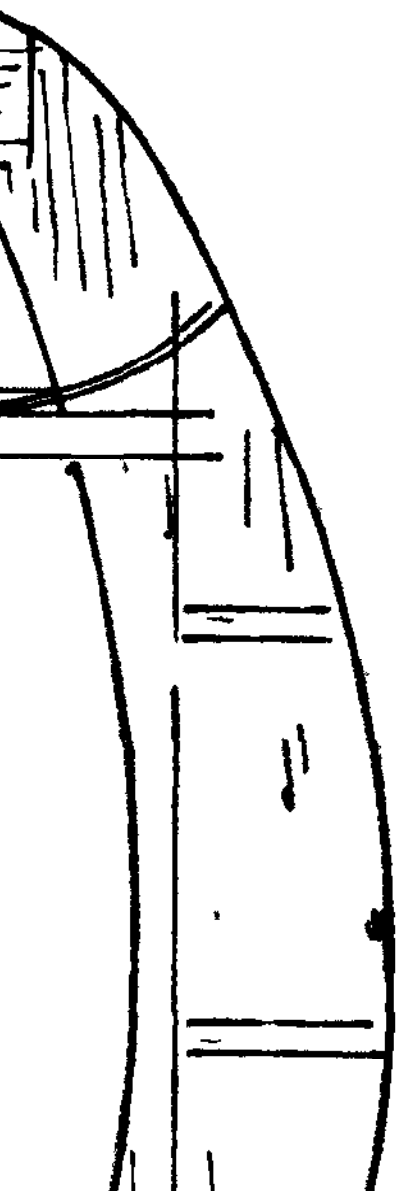

METHOD OF FIXING
LEGS TO FLOAT.

BASIC STRINGER

TOP STRINGER

③

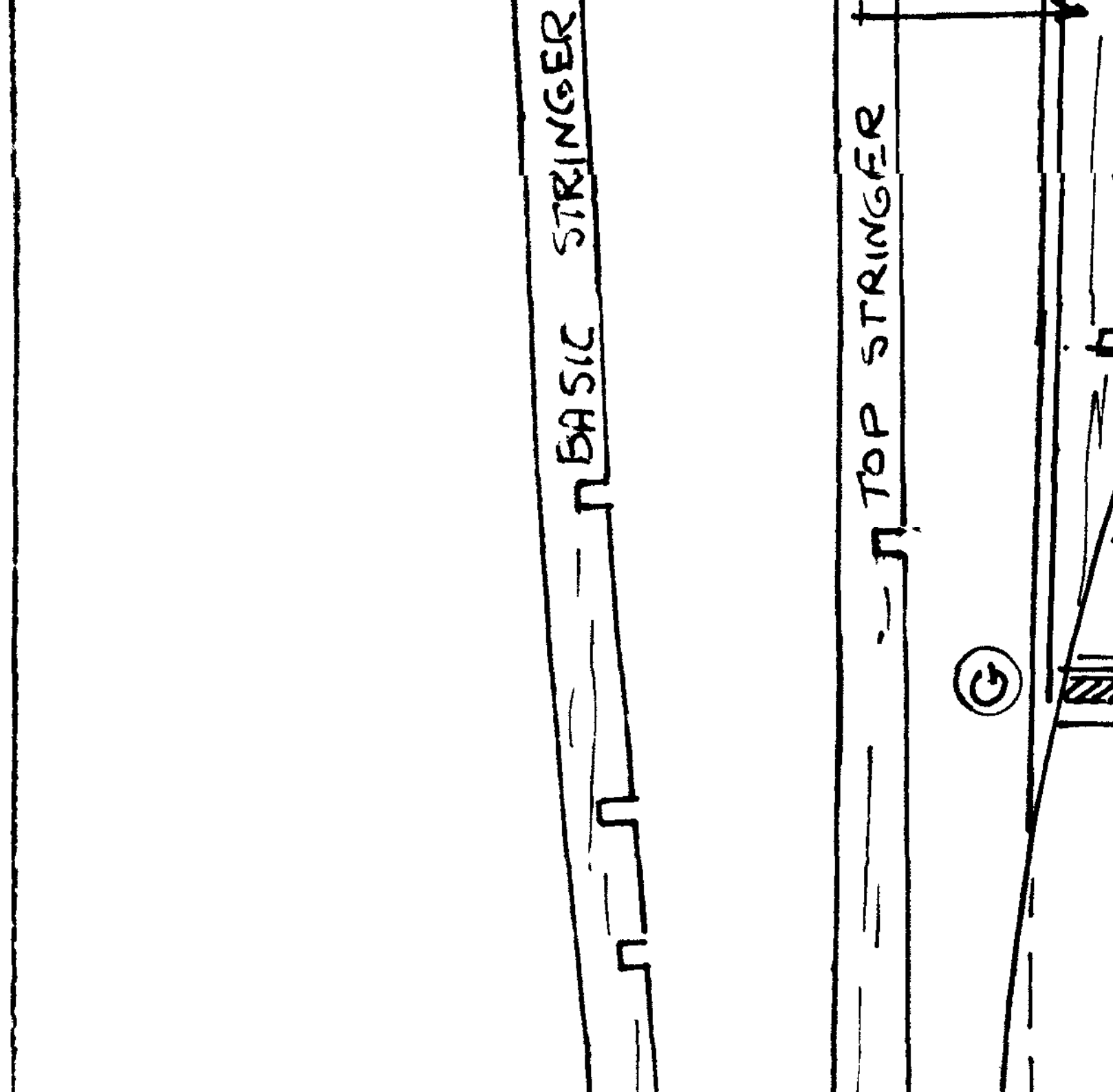

HINGE
CARGO DOOR

(H)



BASIC STRINGER

PORE & AFT

(J)

(F)

TO BALANCE
THIS LINE

w2

H LOWER



INTER S

SECTION OF TE

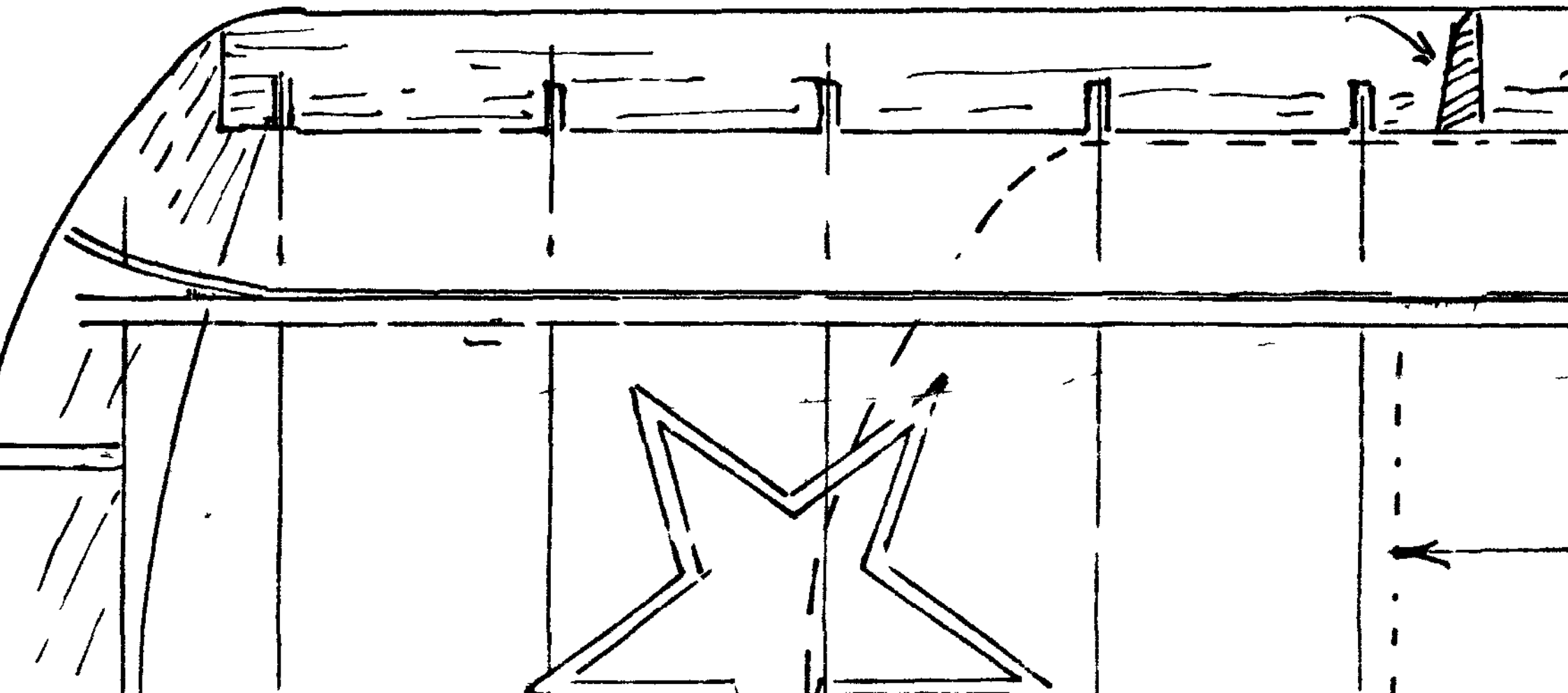

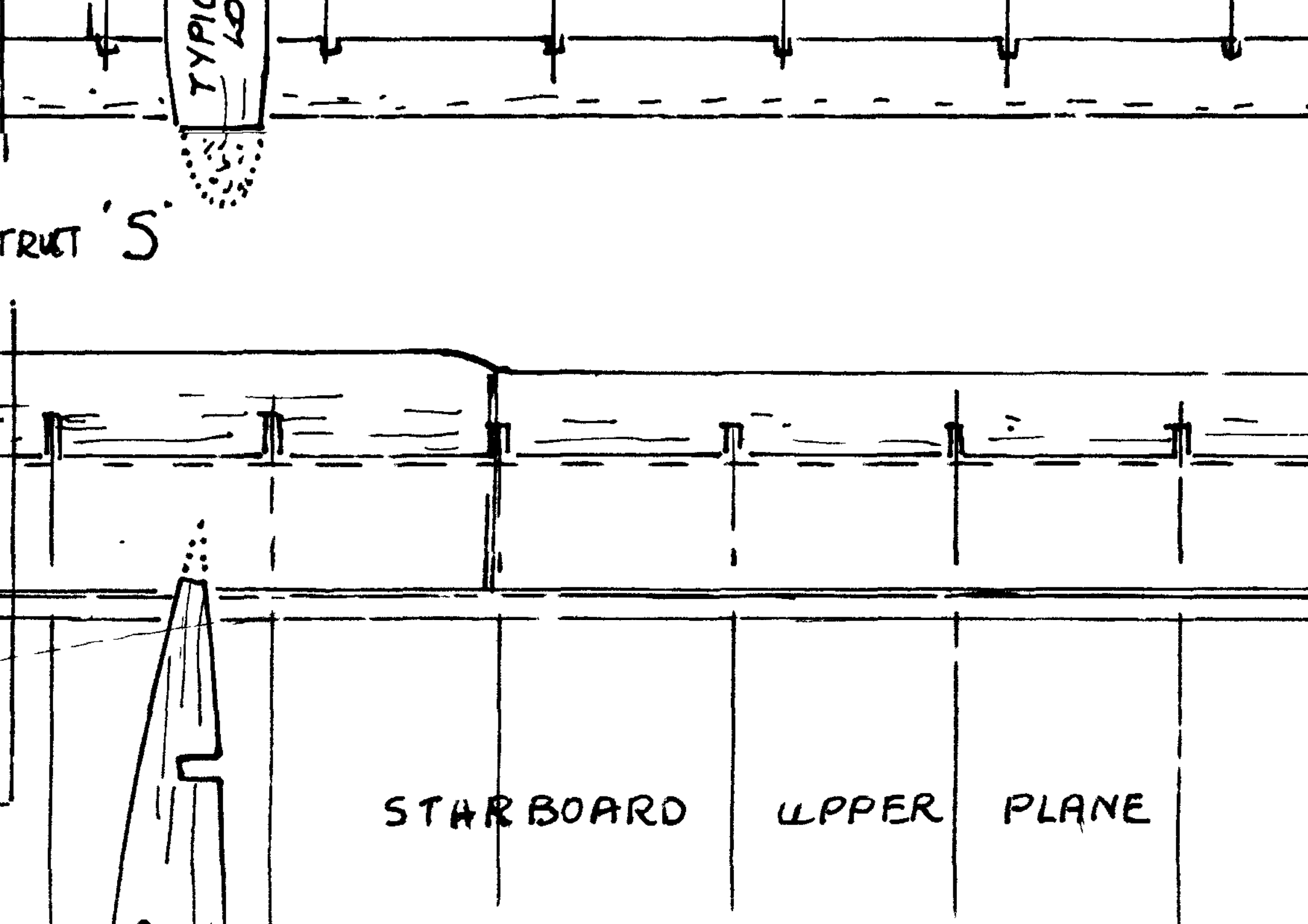

TYPICAL
LD

STRUCT '5'

STARBOARD

UPPER

PLANE

w1

UPPER
VIEW

LOWER
VIEW

D

J

H

G

F

w2

SOLID

w/c
WIRE HOPE

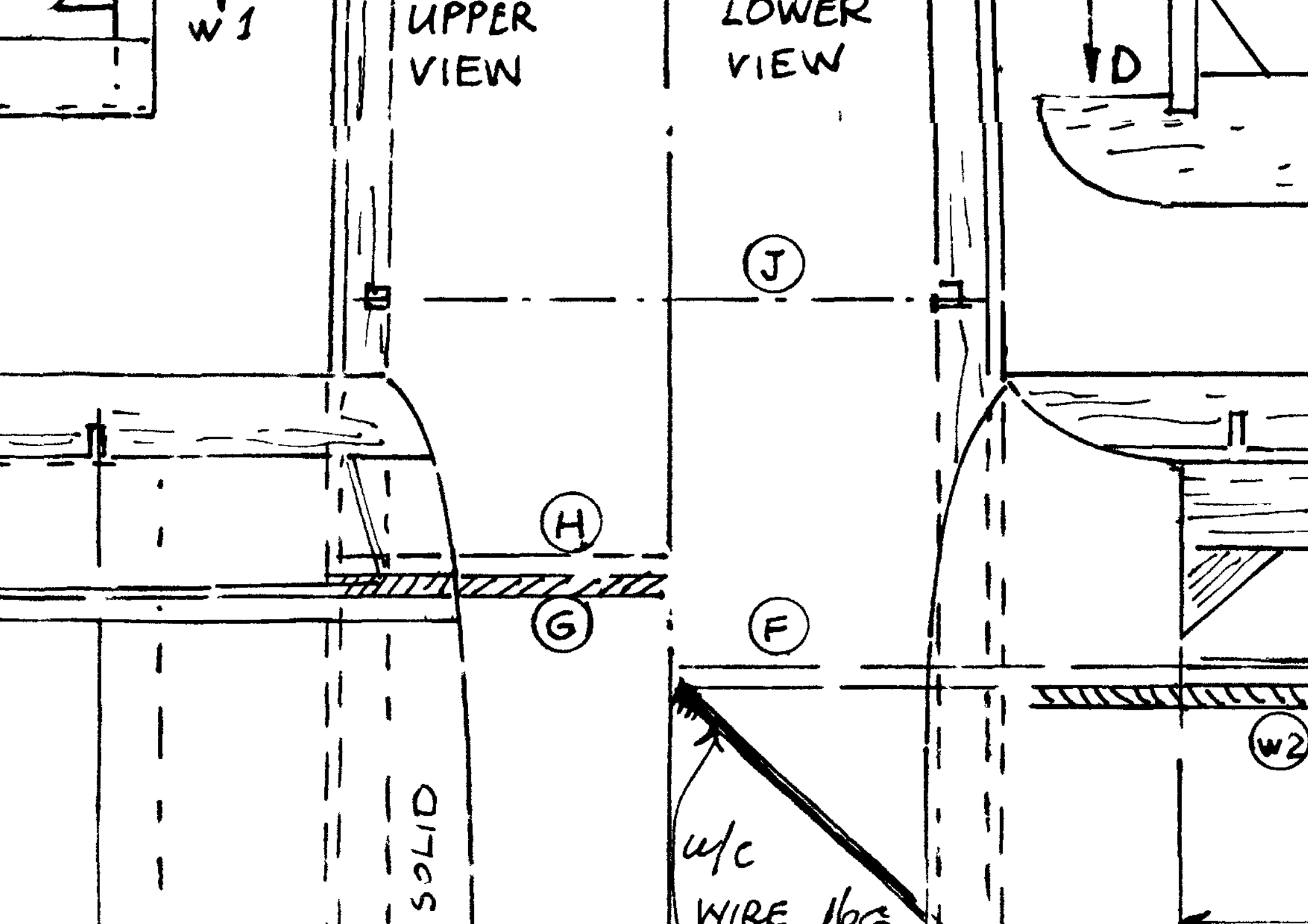

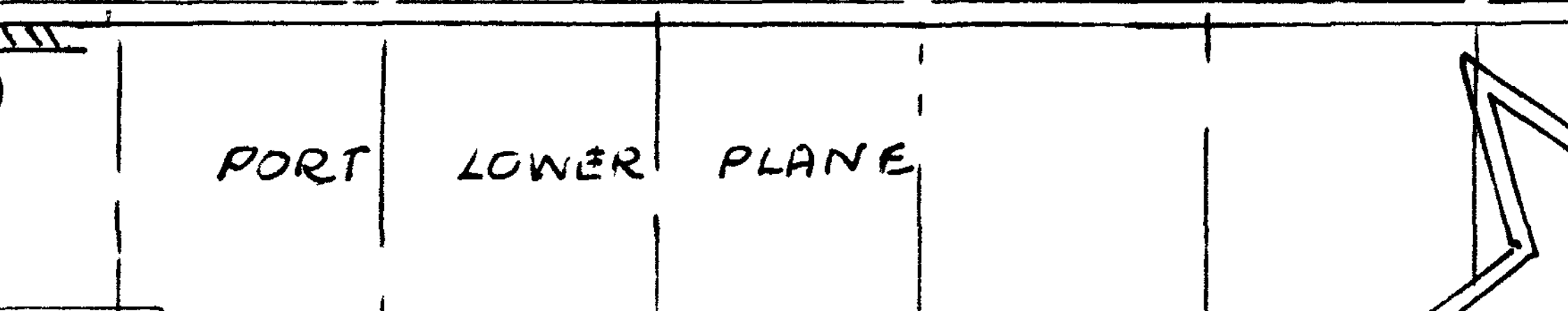
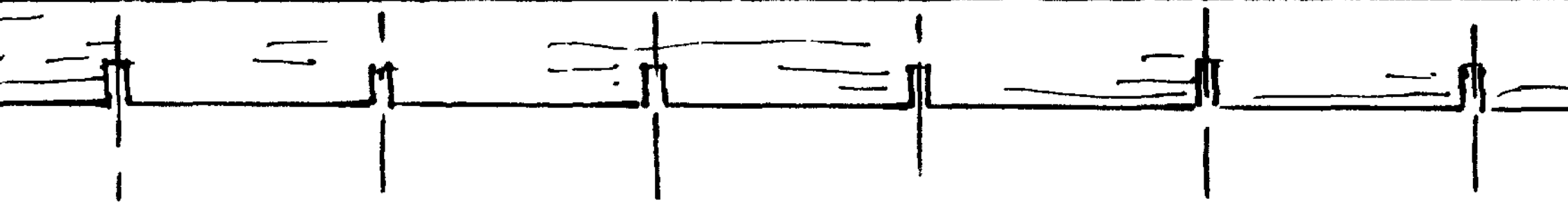
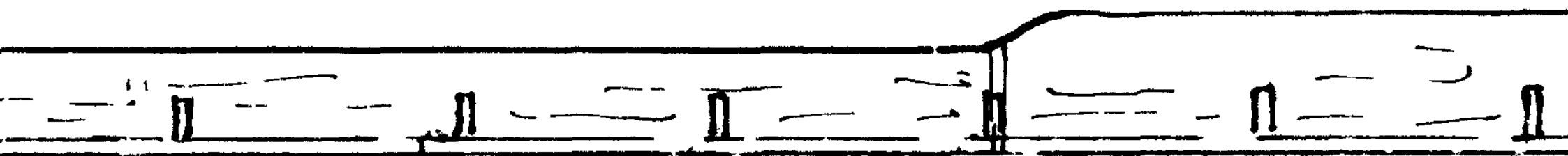
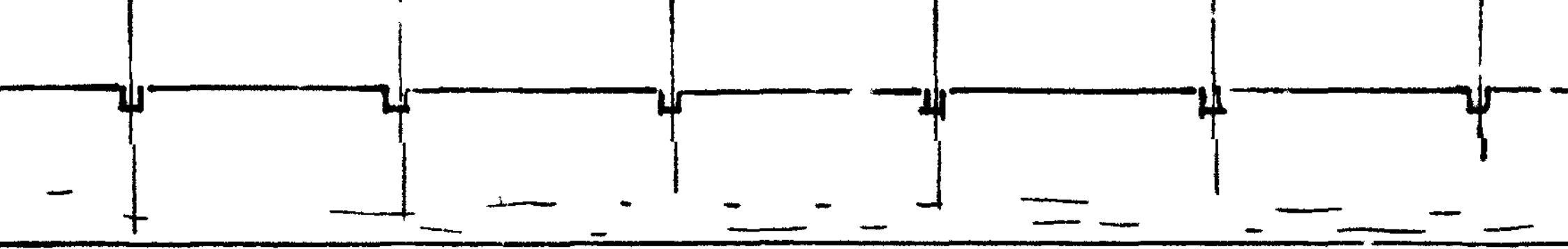

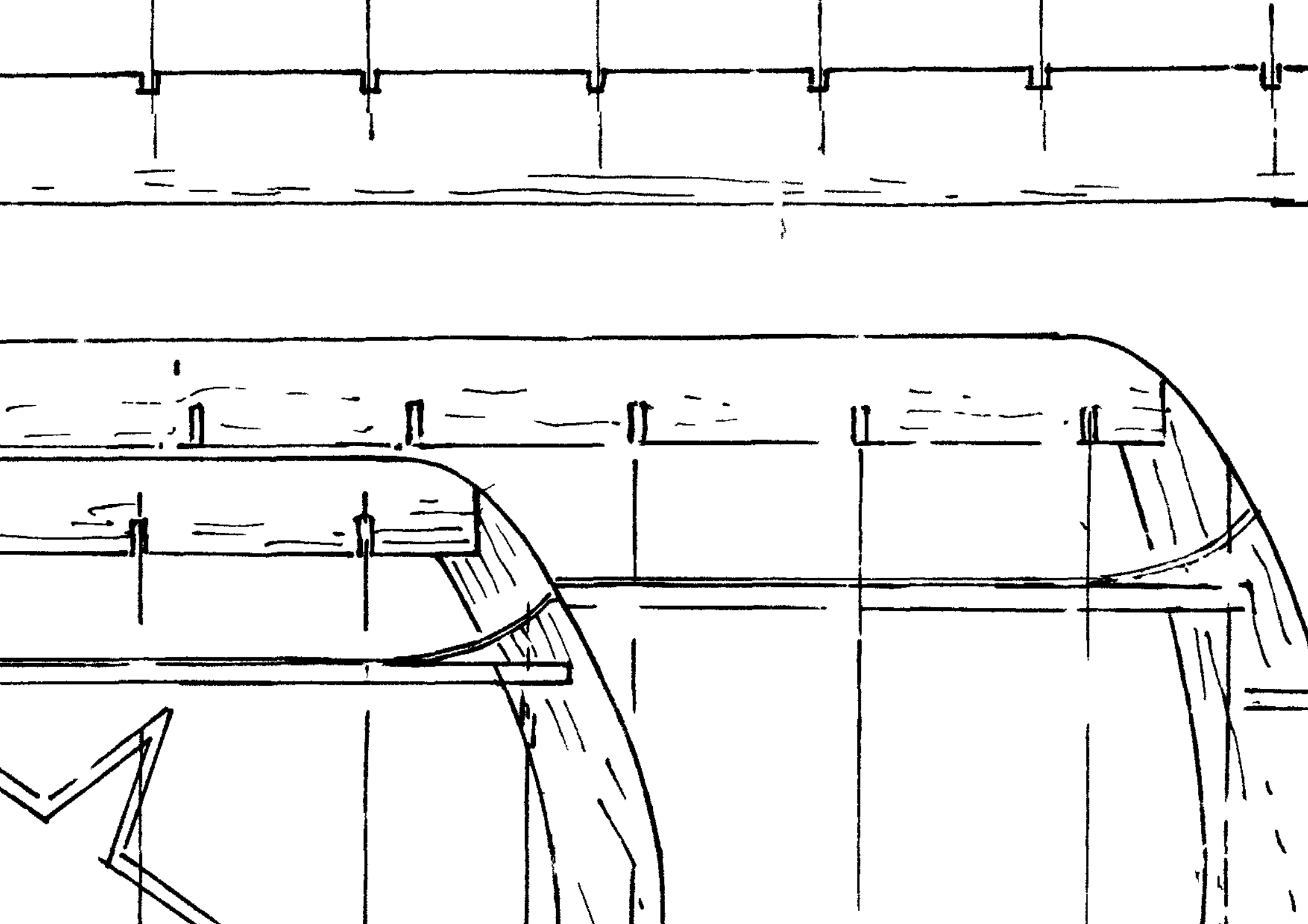

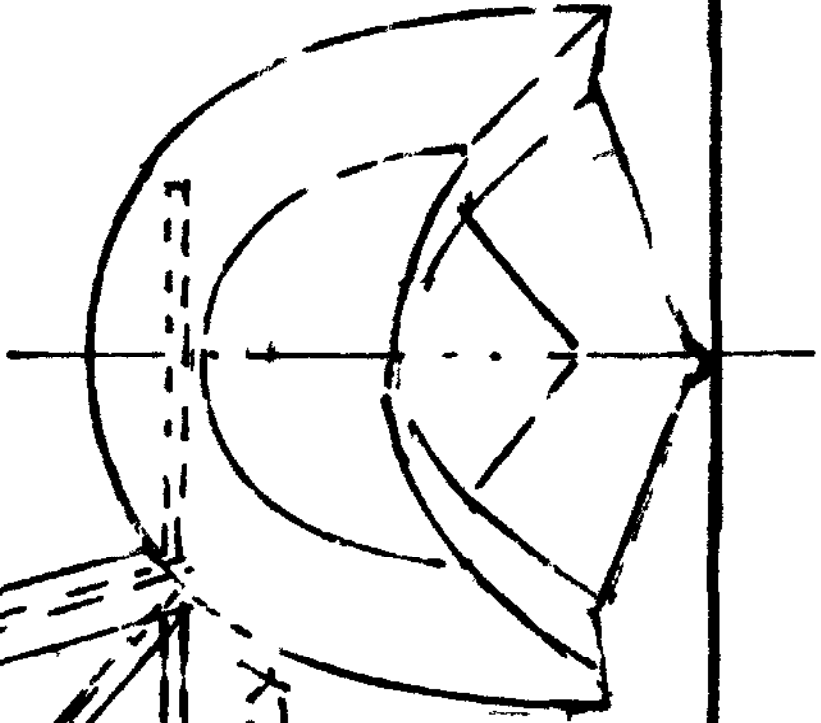
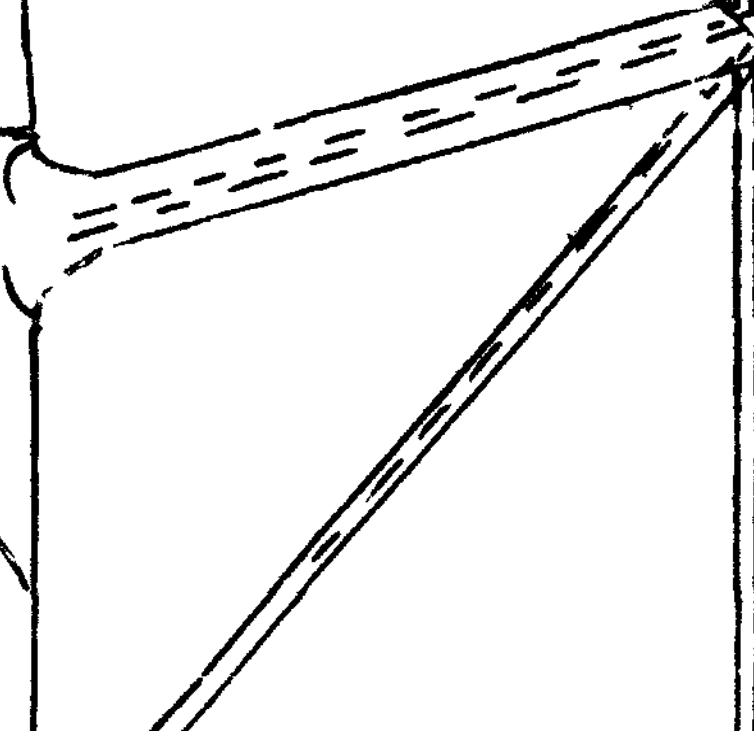

BEAR STRUTS ONLY

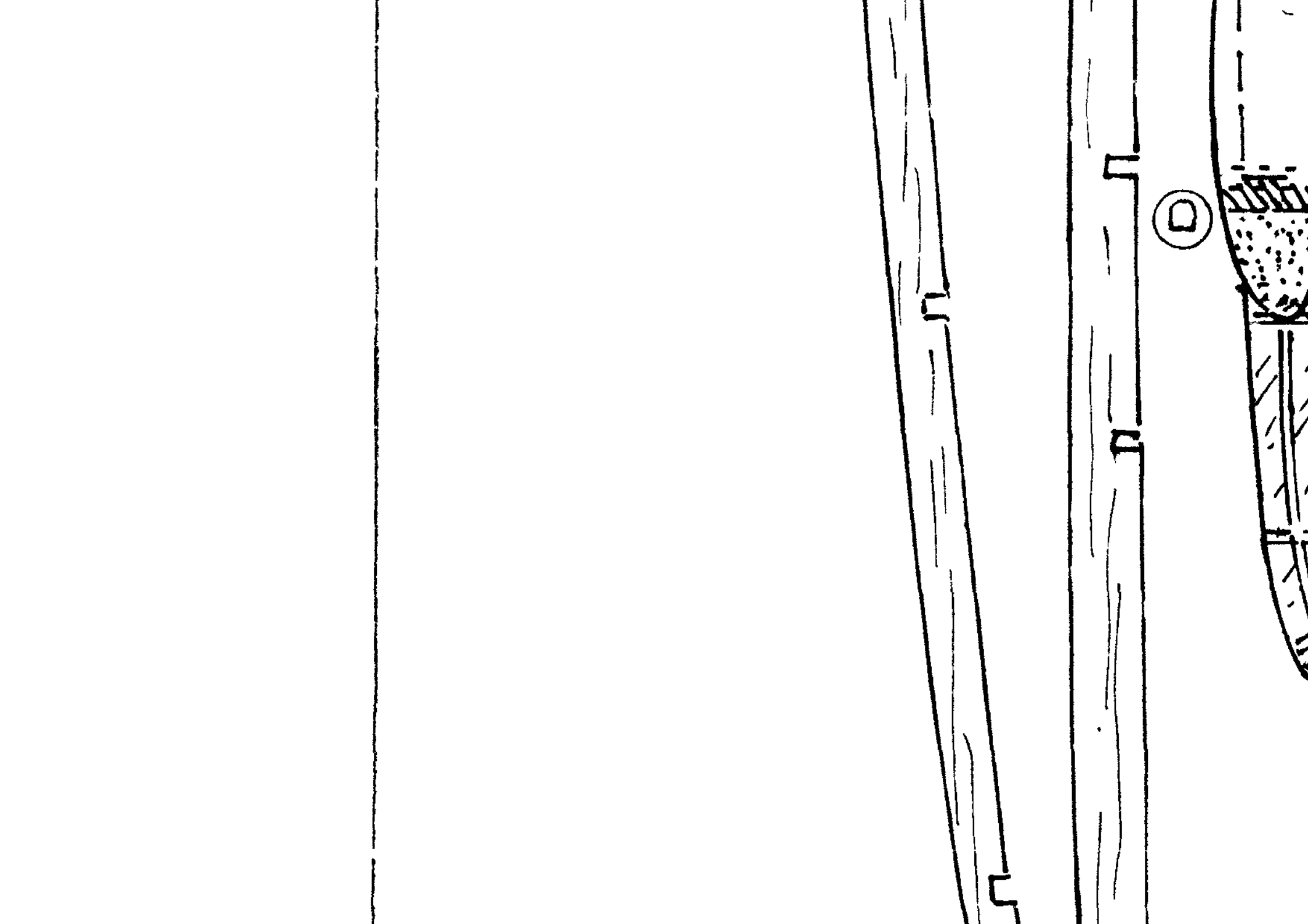

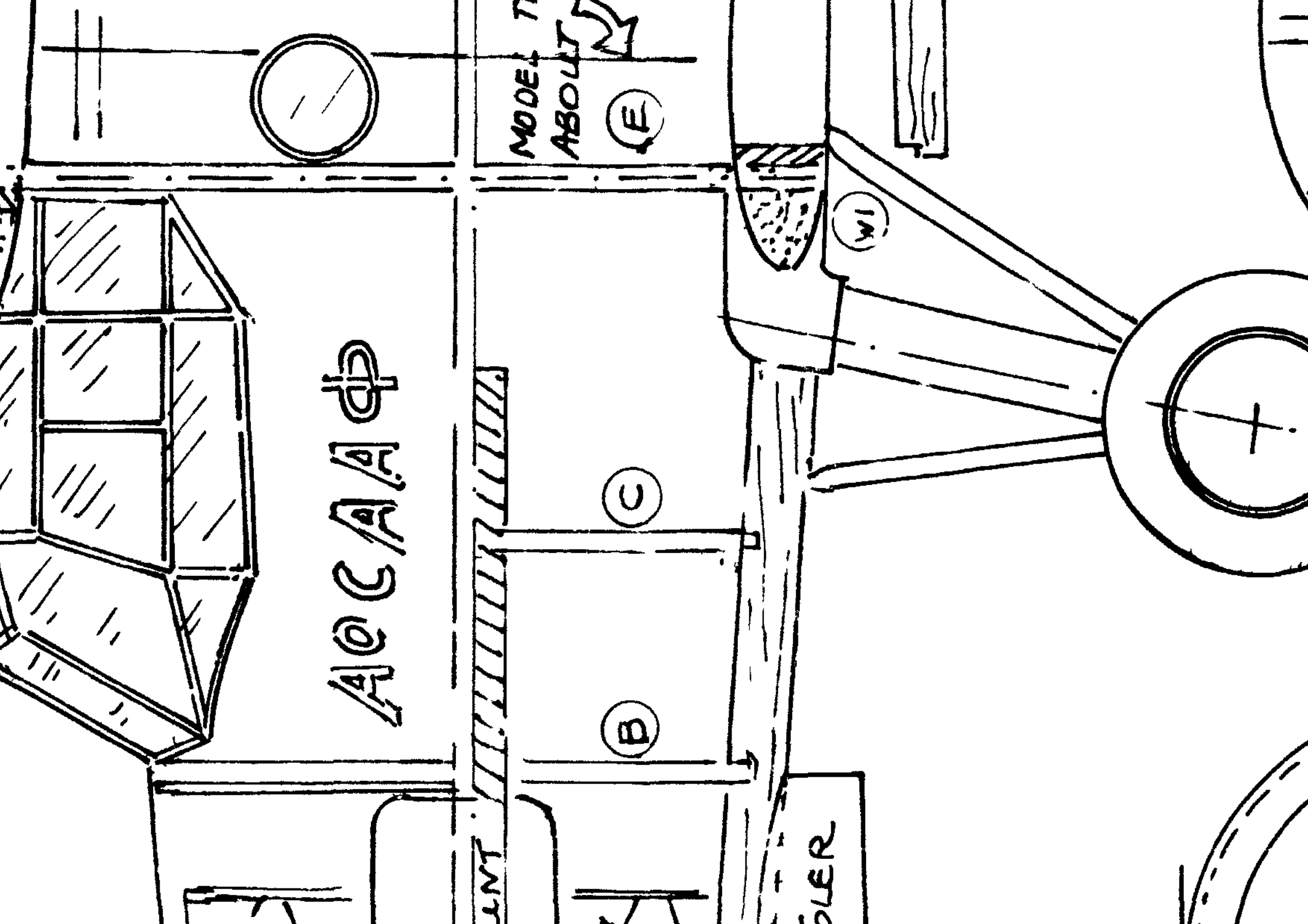

MODEL TO
ABOUT

(E)

(W)

(C)

(B)

A/C/A/A/CP

ANT

PLER

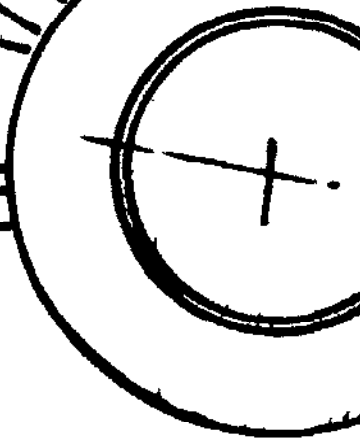

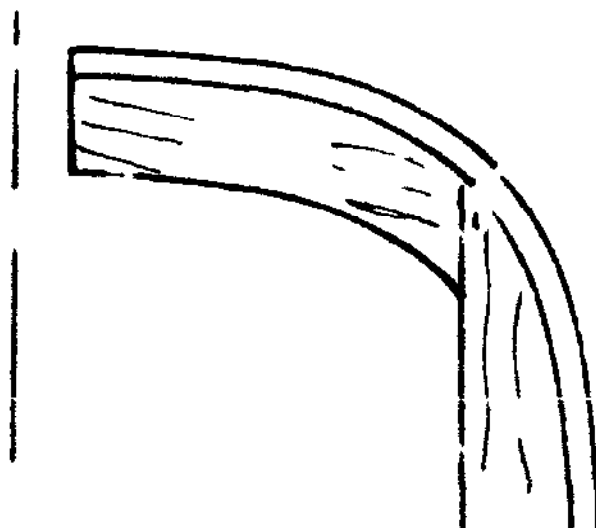
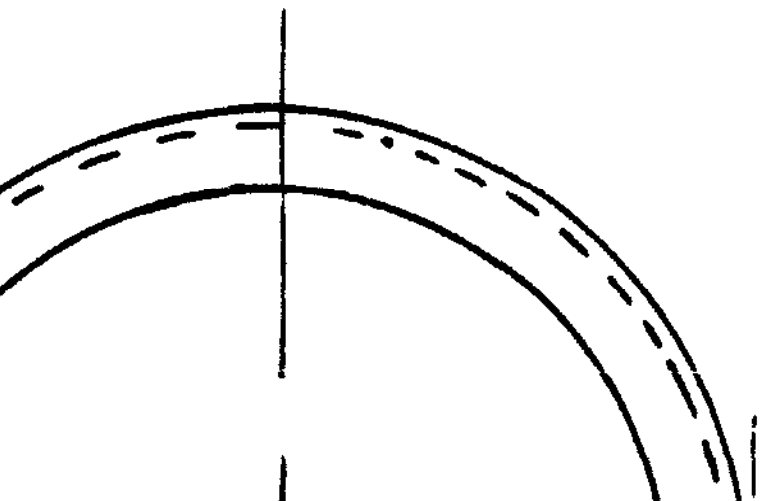
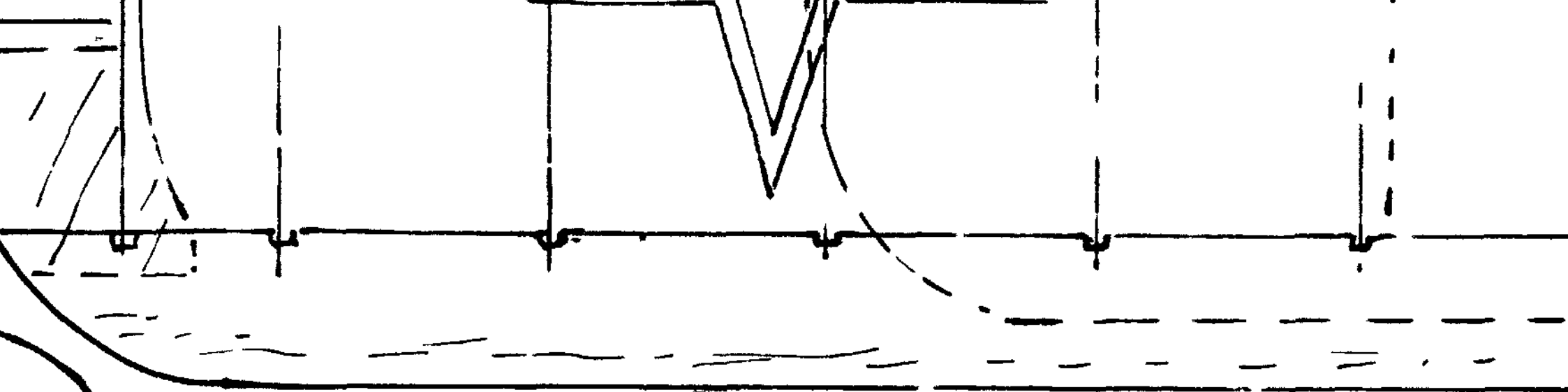

SOLID Balsa
LEADING EDGE →

TYPICAL RIB
UPPER

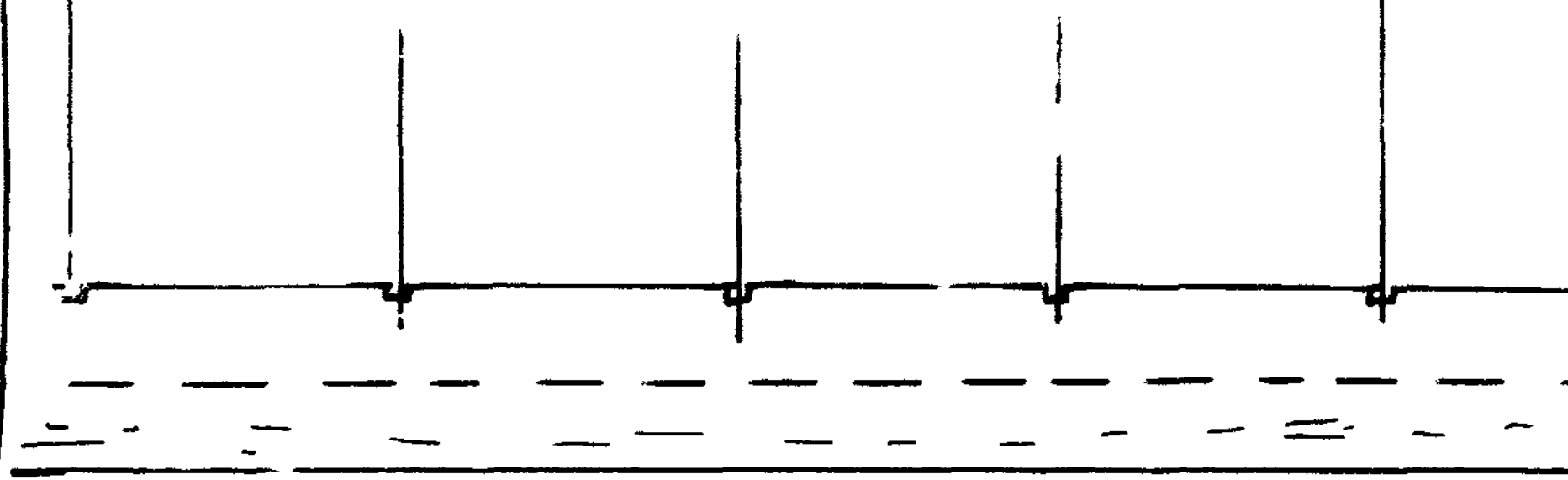

BEARER
THREE PLY

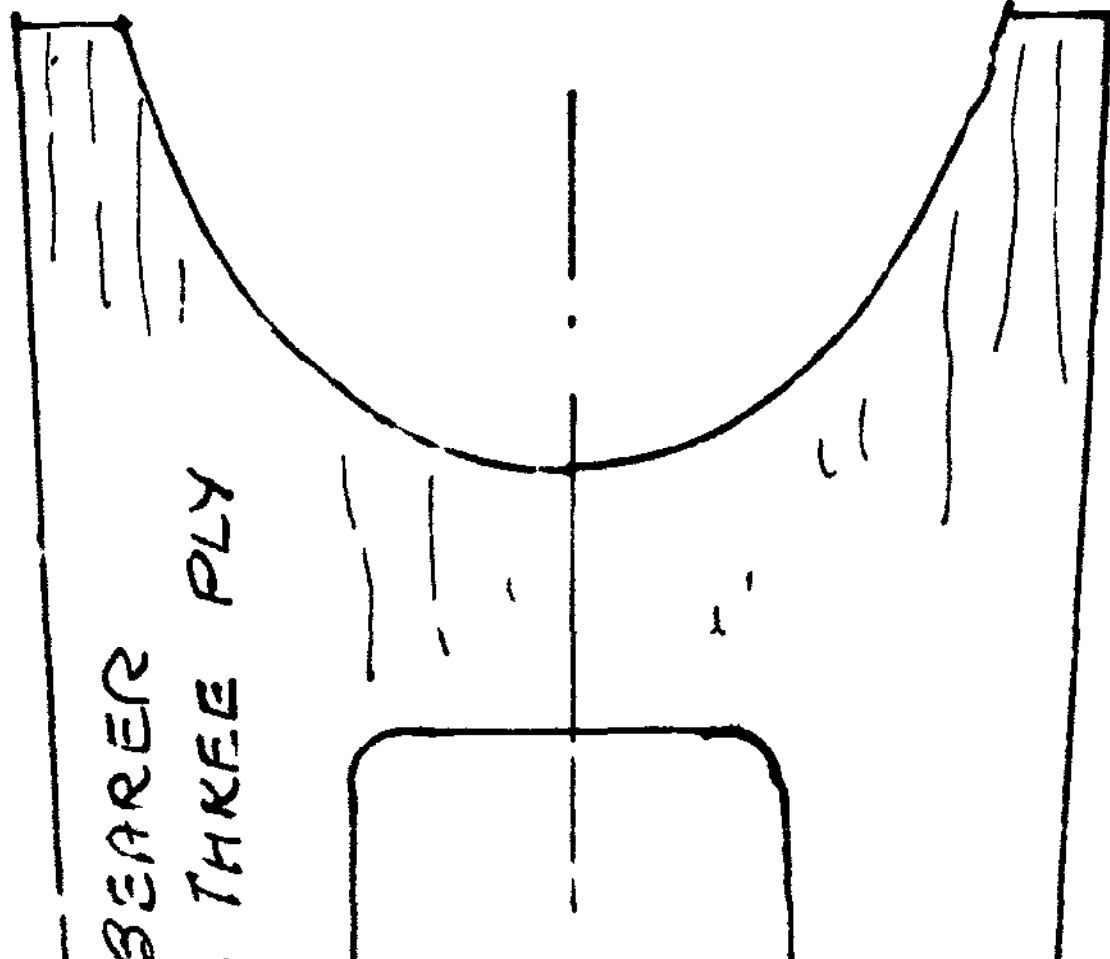

EXT
S

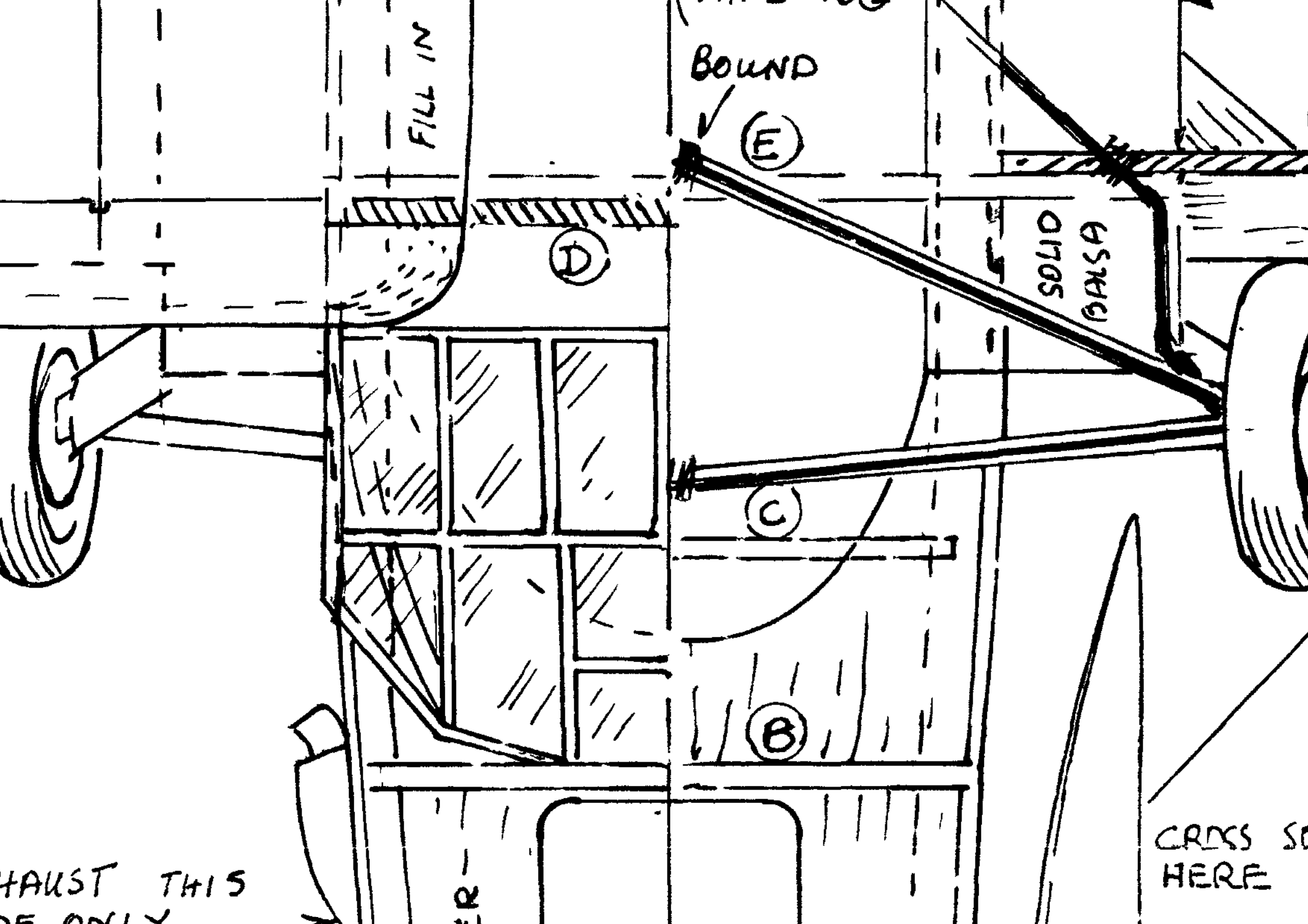

FILL IN

BOUND

(E)

(D)

SOLID BRAG

(C)

(B)

EXHAUST THIS SIDE ONLY

CROSS SECTION HERE

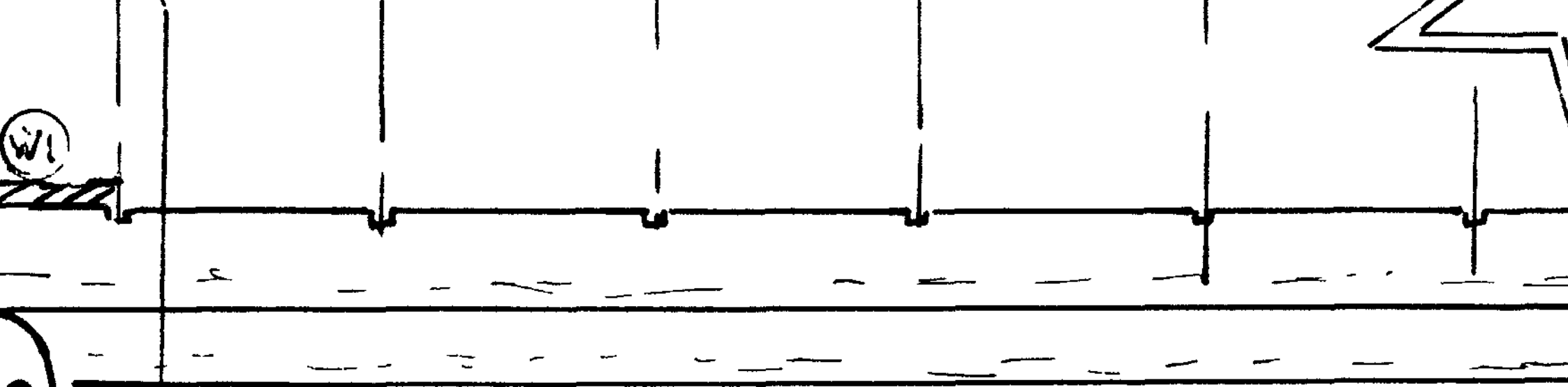

INSTRUCTIONS:- THE MODEL IS BUILT IN TWO

LAY DOWN THE TWO BASIC STRINGERS ON PL
RESPECTIVE FORMERS. ADD TOP STRINGER & DI
VERTICAL IN ORDER TO ALIGN WINGS. WHICH

LIFT FROM BOARD & ADD LOWER FORM
PREVIOUSLY ADDING ENGINE MOUNT, PLY

TAIL UNIT & UNDERCARRIAGE SHOULD

COVER COMPLETE FUSELAGE WITH $\frac{3}{16}$ "

SECTION

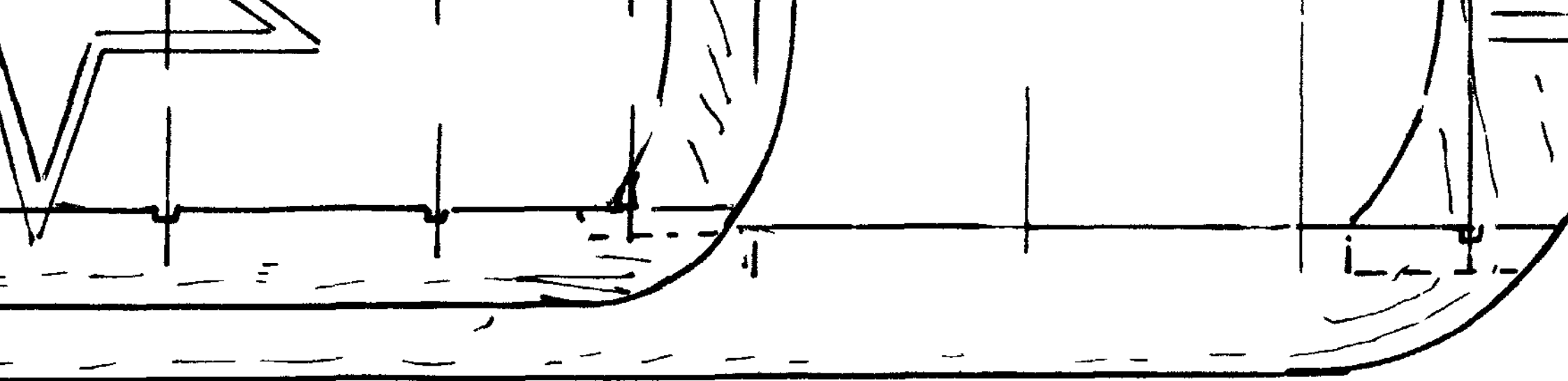

HALVES, UPPER & LOWER.

LAY ON BUILDING BOARD & ERECT TOP HALVES OF
STANCE PIECES. FORMERS E & H MUST BE SQUARE AND
CAN NOW BE ADDED, NOTING DIEDRAL.

ERS, JOINING TOGETHER WITH LOWER STRINGER.

WOOD NOSERING 'A' CAN NOW BE FIXED.

NOW BE FITTED.

OR $\frac{1}{16}$ " MEDIUM Balsa PLANKING ABOUT $\frac{1}{4}$ " WIDE, OR

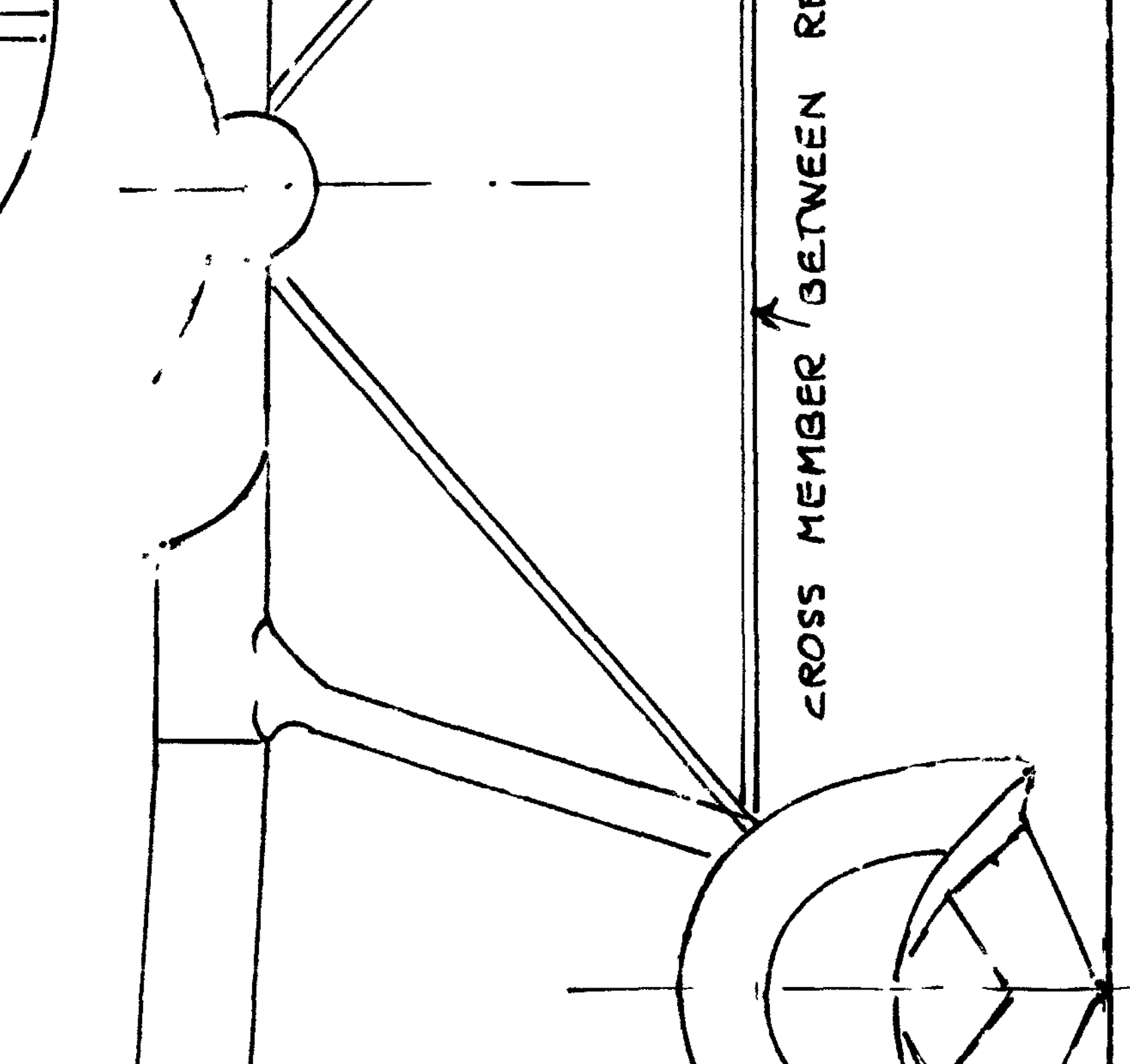

CROSS MEMBER BETWEEN R...

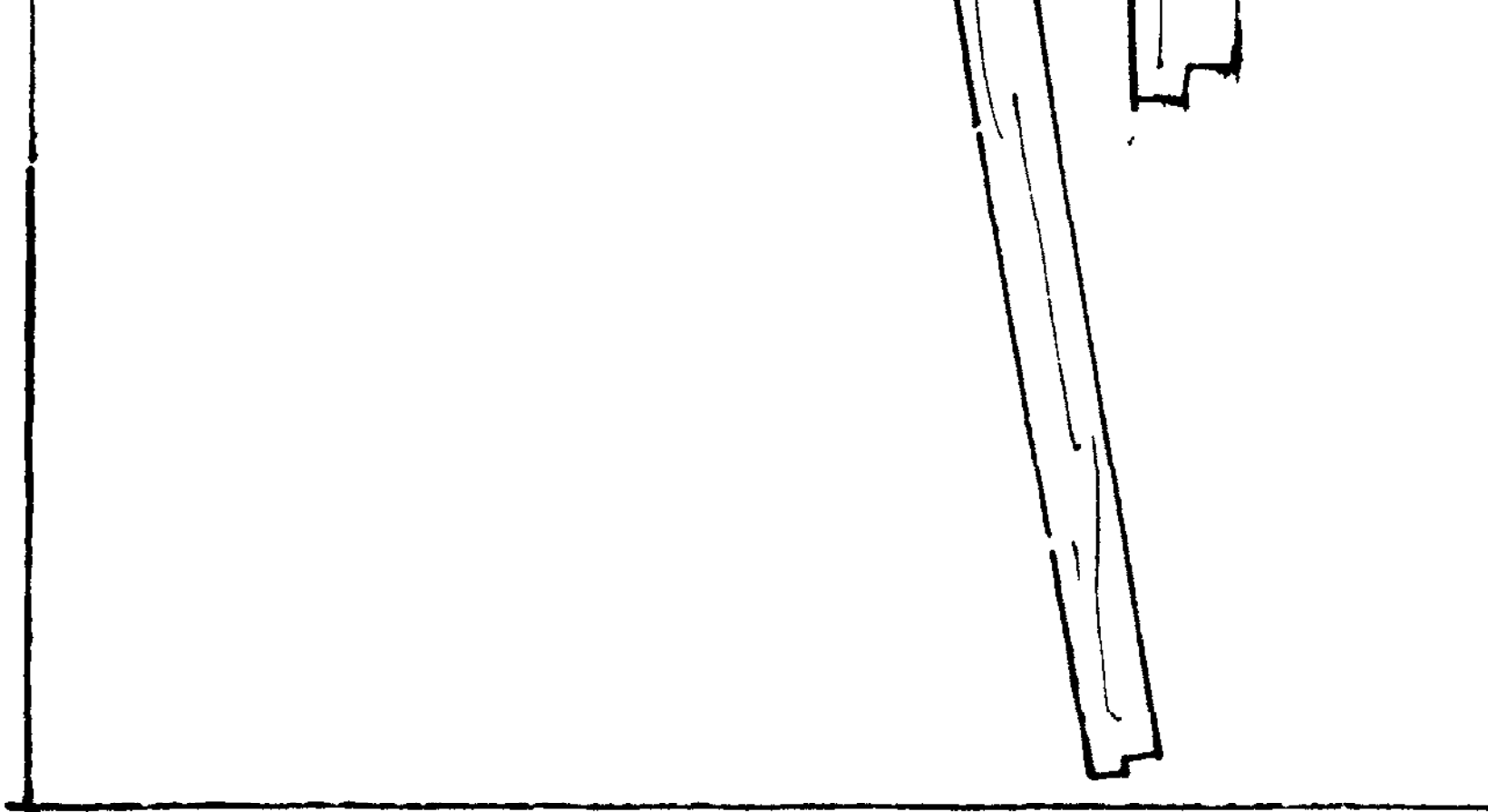

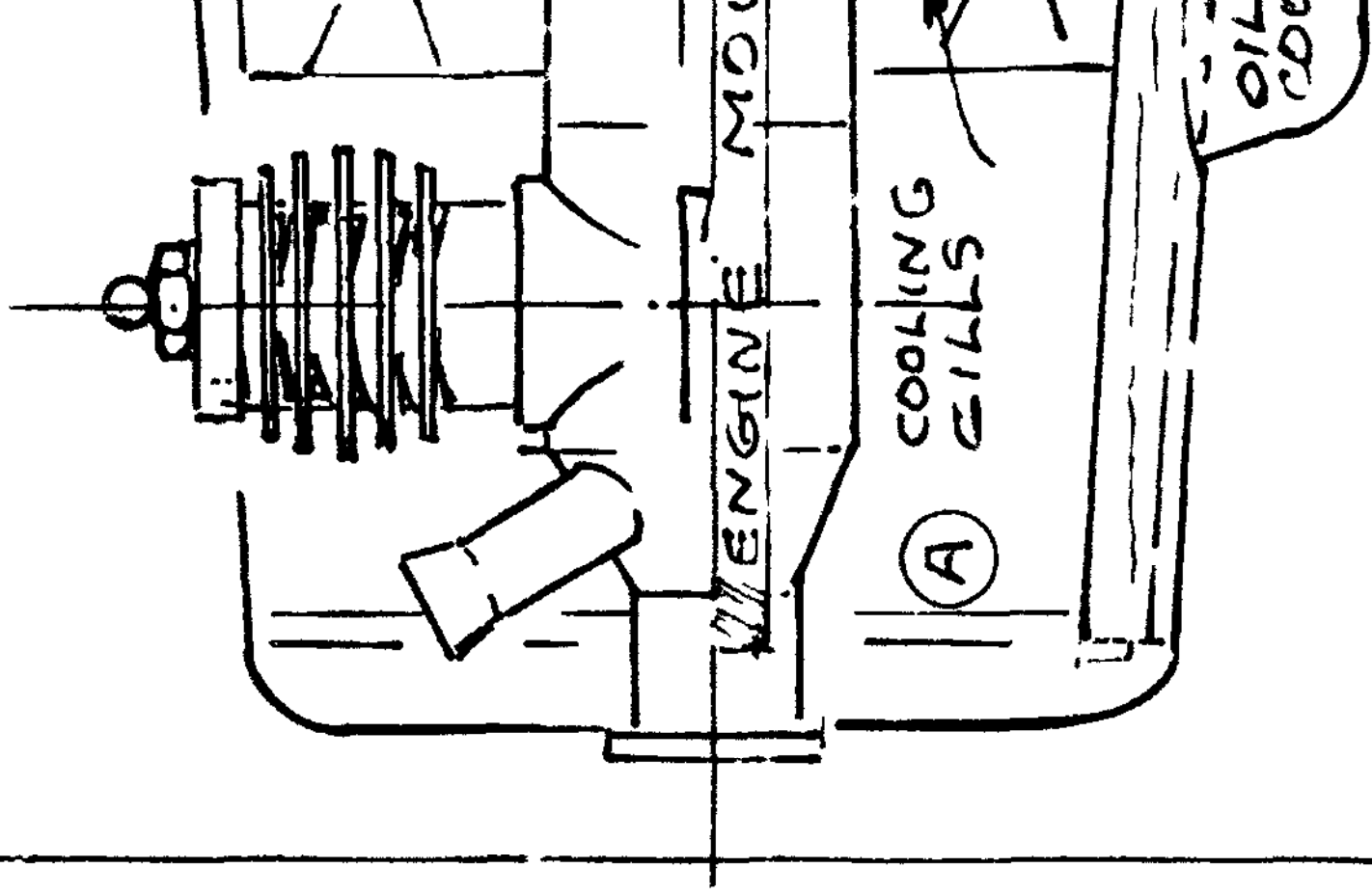

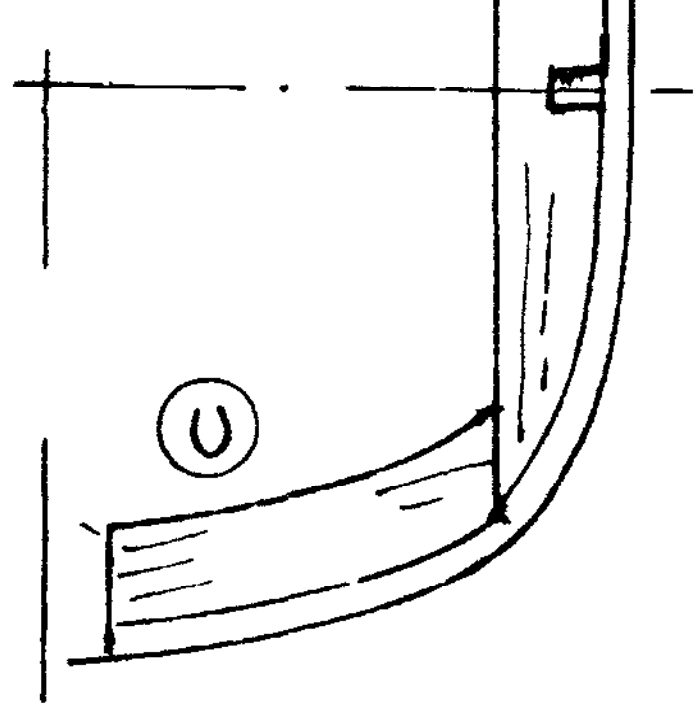
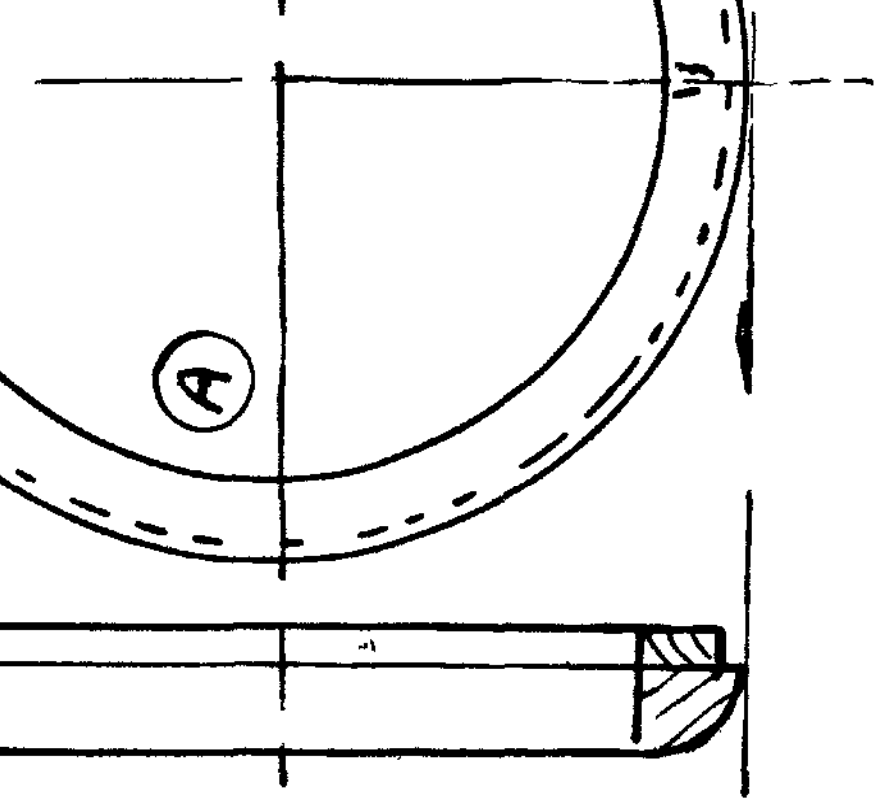

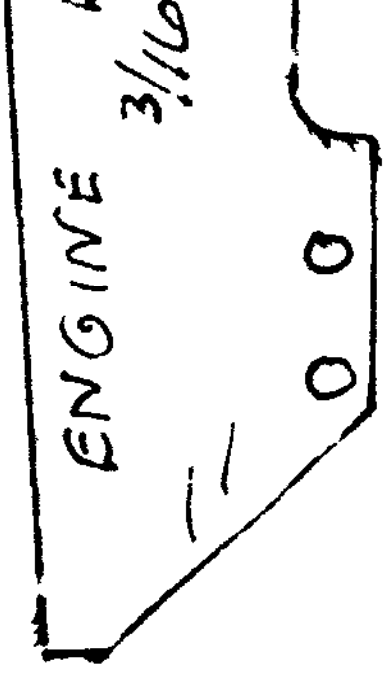

CUT TO SUIT

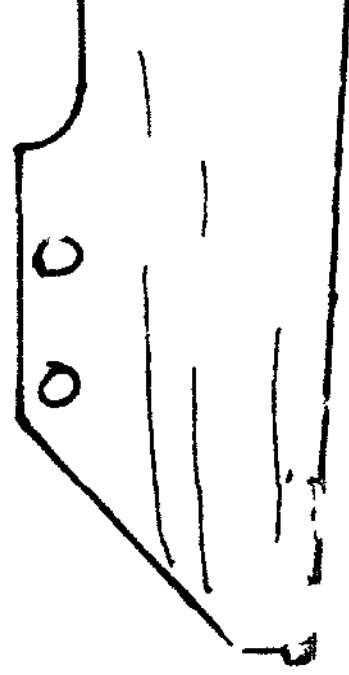

E DINK

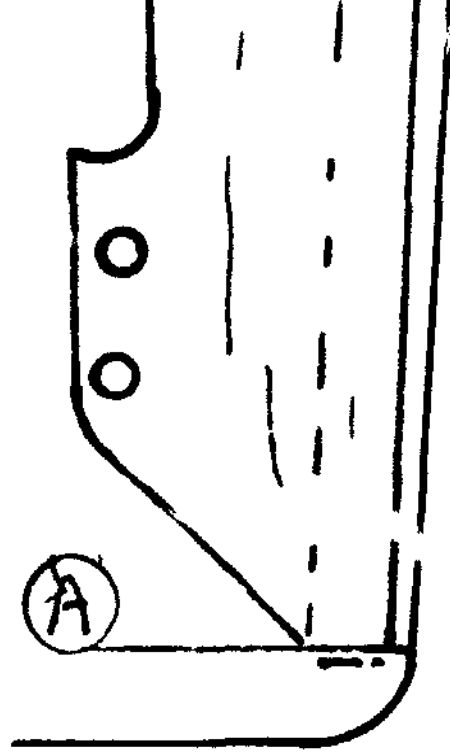
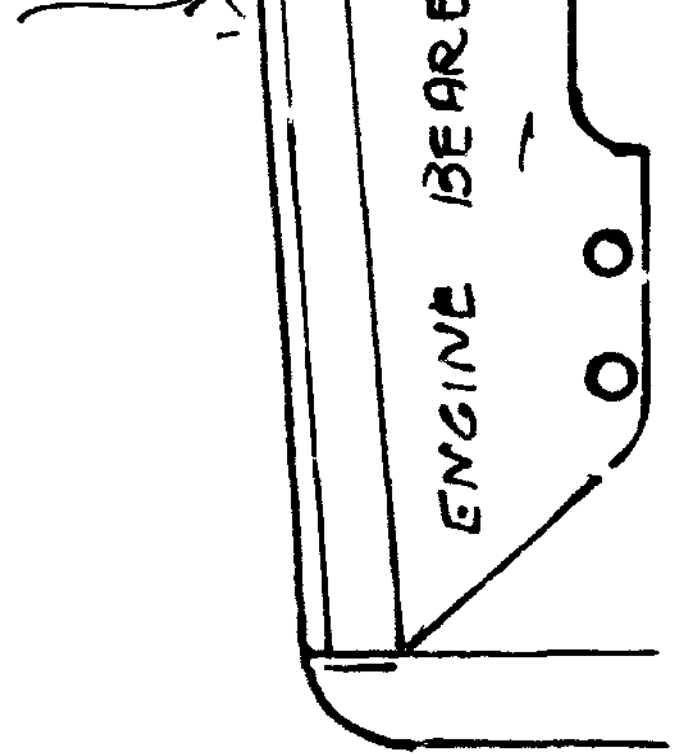

LESS WHEN COVERING TOP & BOTTOM CURVING

COVER WITH MEDIUM TISSUE 2 OR 3 C

THIS MODEL - SKY BLUE, ALL UNDER SU

LETTERING PALE YELLOW. STARS RED C

110
ED SHOULDERS. SAND TO SMOOTH PROFILE

COATS OF CLEAR DOPE AND COLOUR TO SUIT.

URFACES, DARK OLIVE GREEN UPPER SURFACES.

OUTLINED IN WHITE.

