



ROYAL PRODUCTS CORP.

LOCKHEED

P-38 Lightning

SHEET 1 of 2

SCALE 1/32" = 1'
 ENGINES 35-61 Twin
 WING SPAN 74 1/4"
 WING AREA 895 Sq. In.
 LENGTH 50-3/4"
 WEIGHT 3-10 lbs.
 CONTROL 4-6 Channel

LOCKHEED P-38L SPECIFICATIONS

Span, 52 ft.; length, 37 ft. 10 in.; height, 12 ft. 10 in.; wing area, 328 sq. ft. Empty weight, 14,100 lbs. combat loaded, 17,500 lbs. Two Allison V-1710-111-113 line-12 radial engines each developing 1425 h.p. at sea level and 26,500 ft. and 1600 h.p. under war emergency conditions at 26,500 ft. Maximum speed, 360 M.P.H. at 5000 ft.; 300 M.P.H. at 15,000 ft. Service ceiling, 40,000 ft.; maximum range of sea level, 1900 miles; at 30,000 ft., 2200 miles.

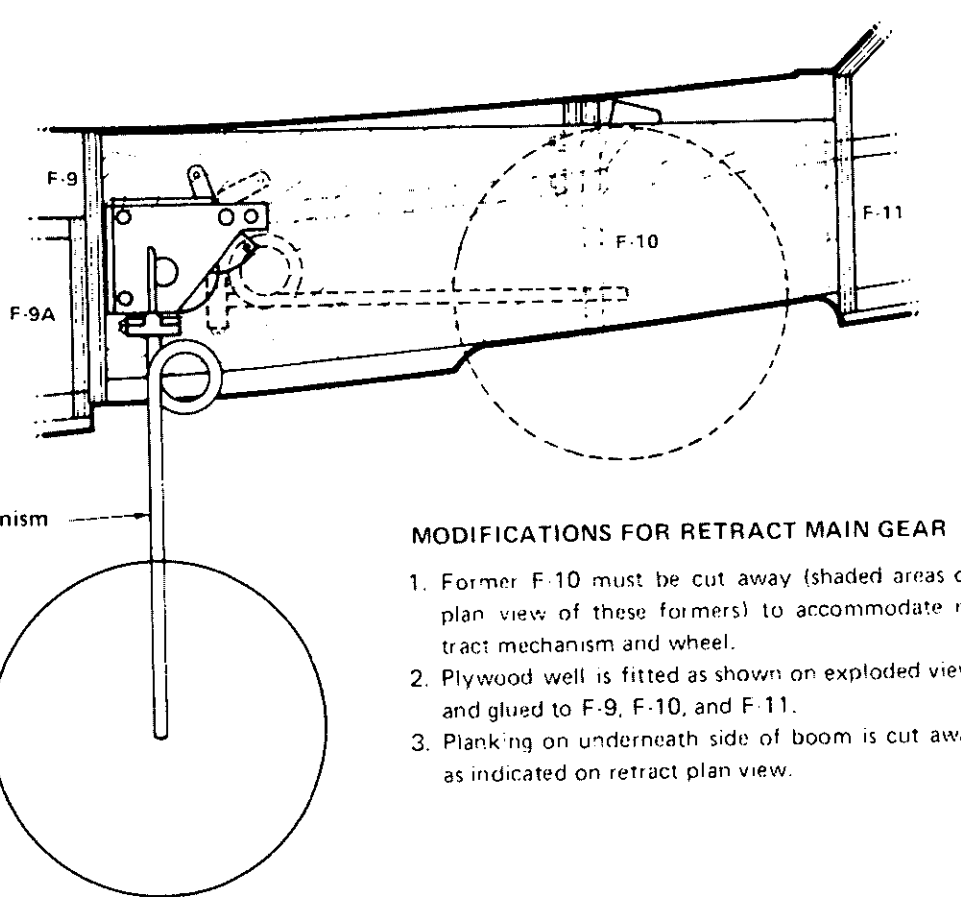
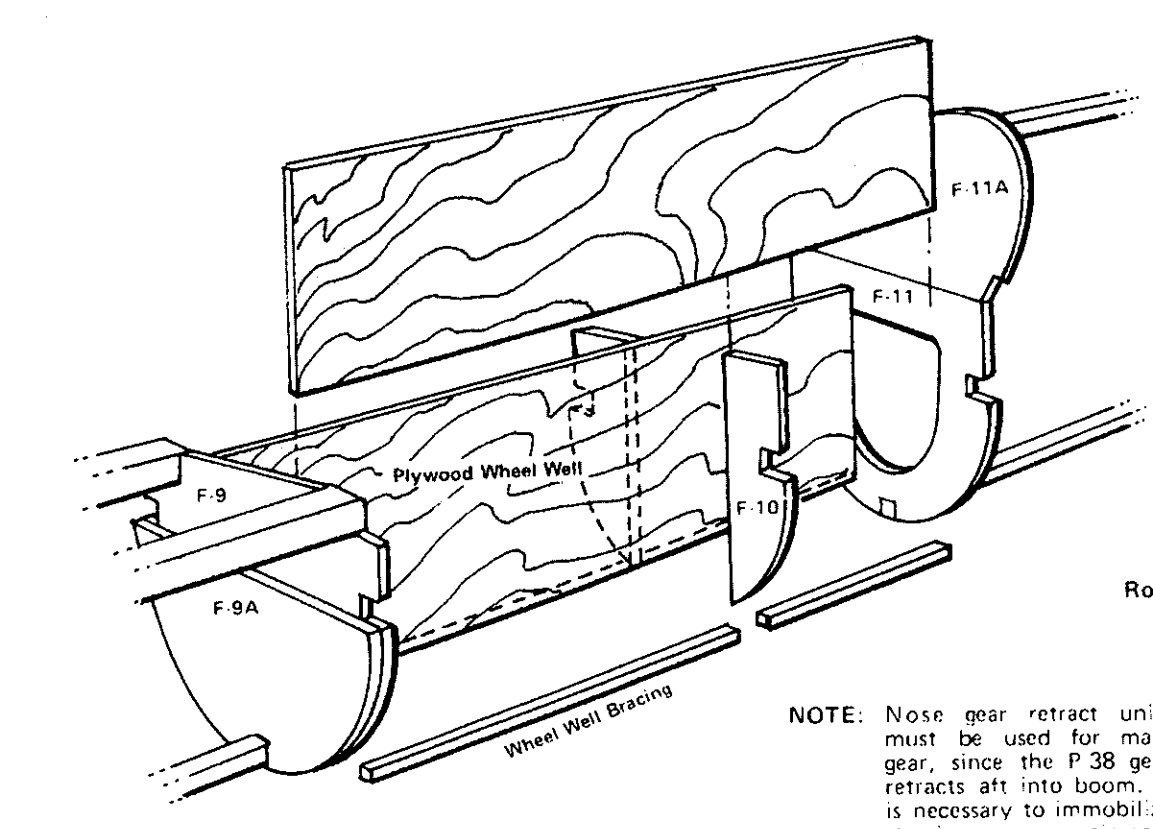
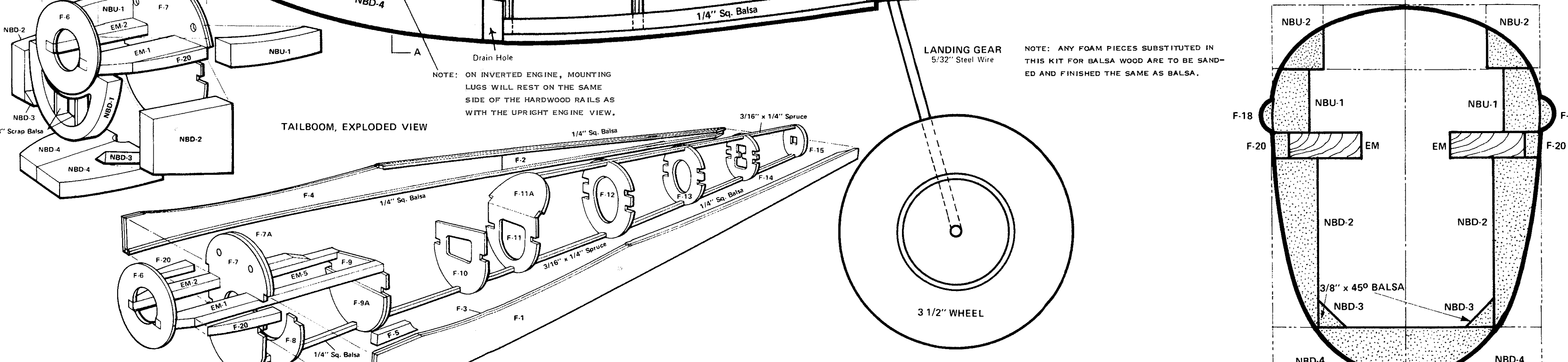
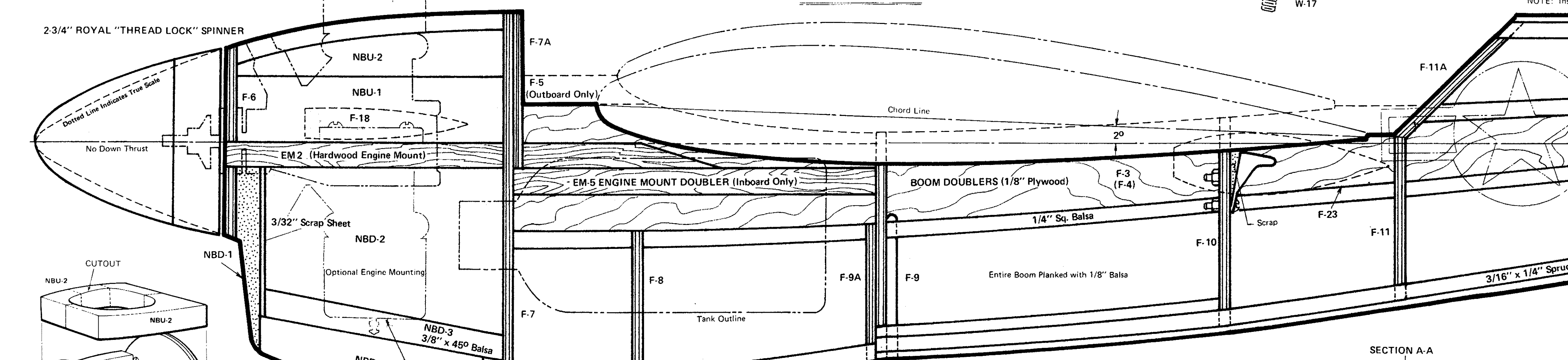
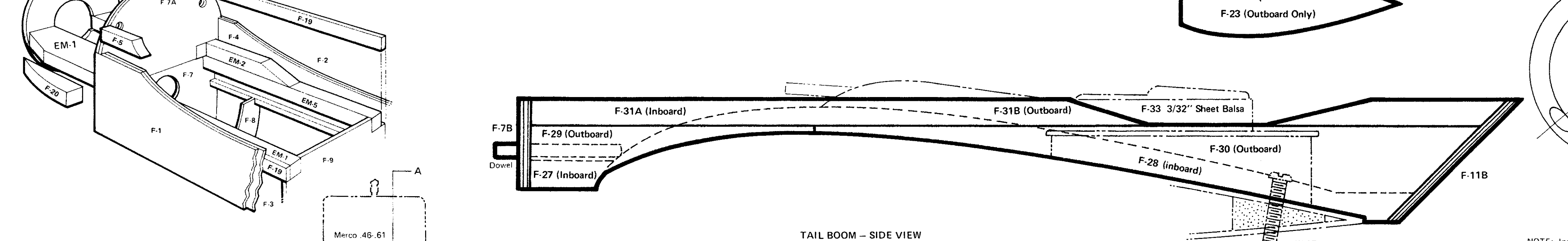
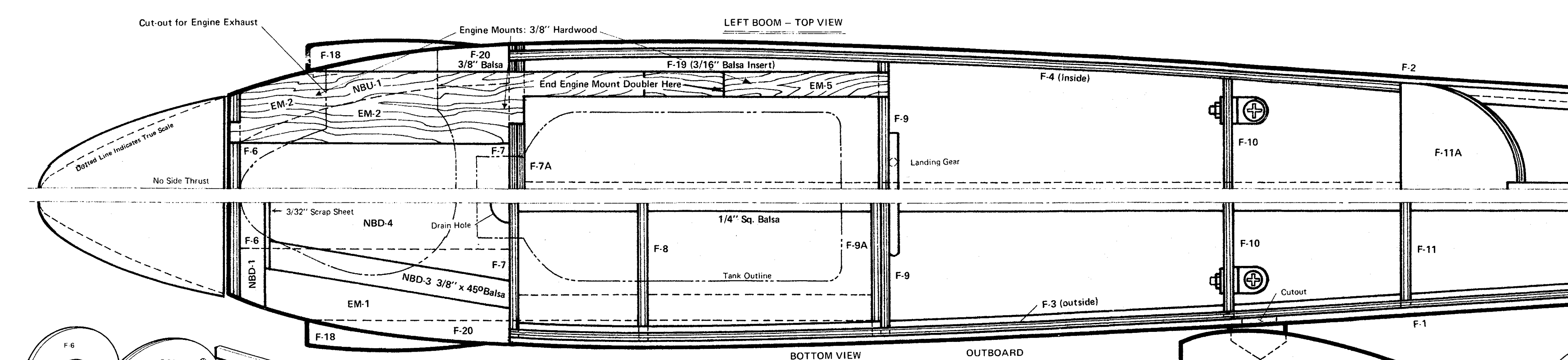
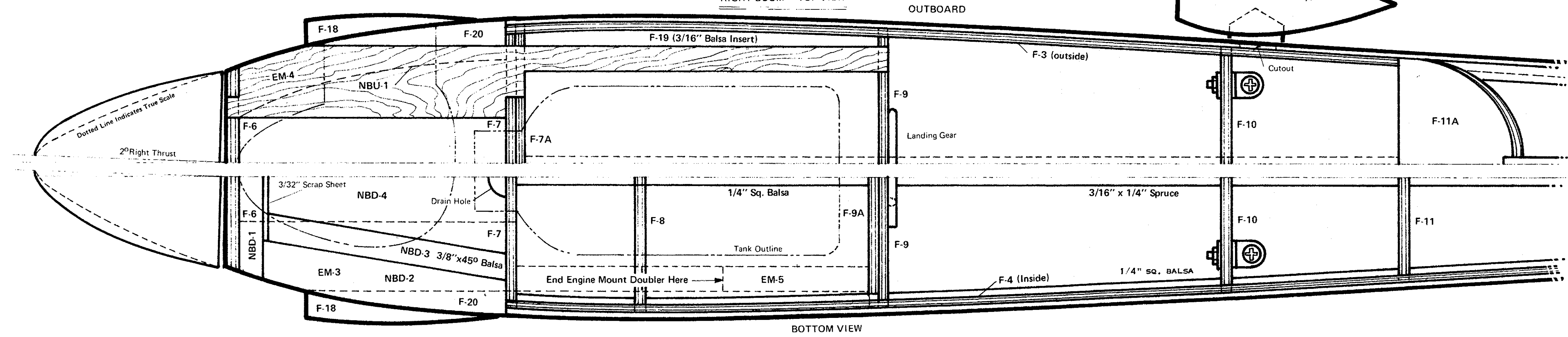
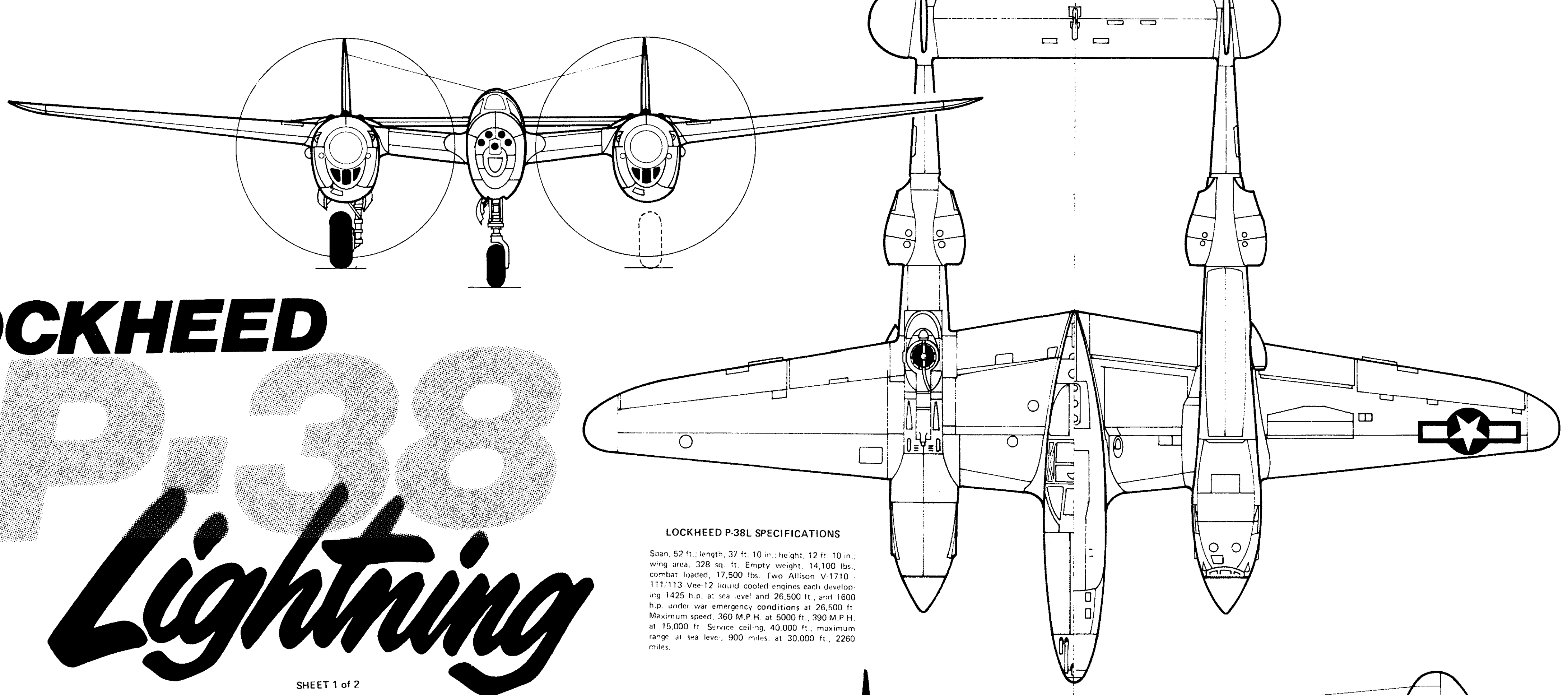
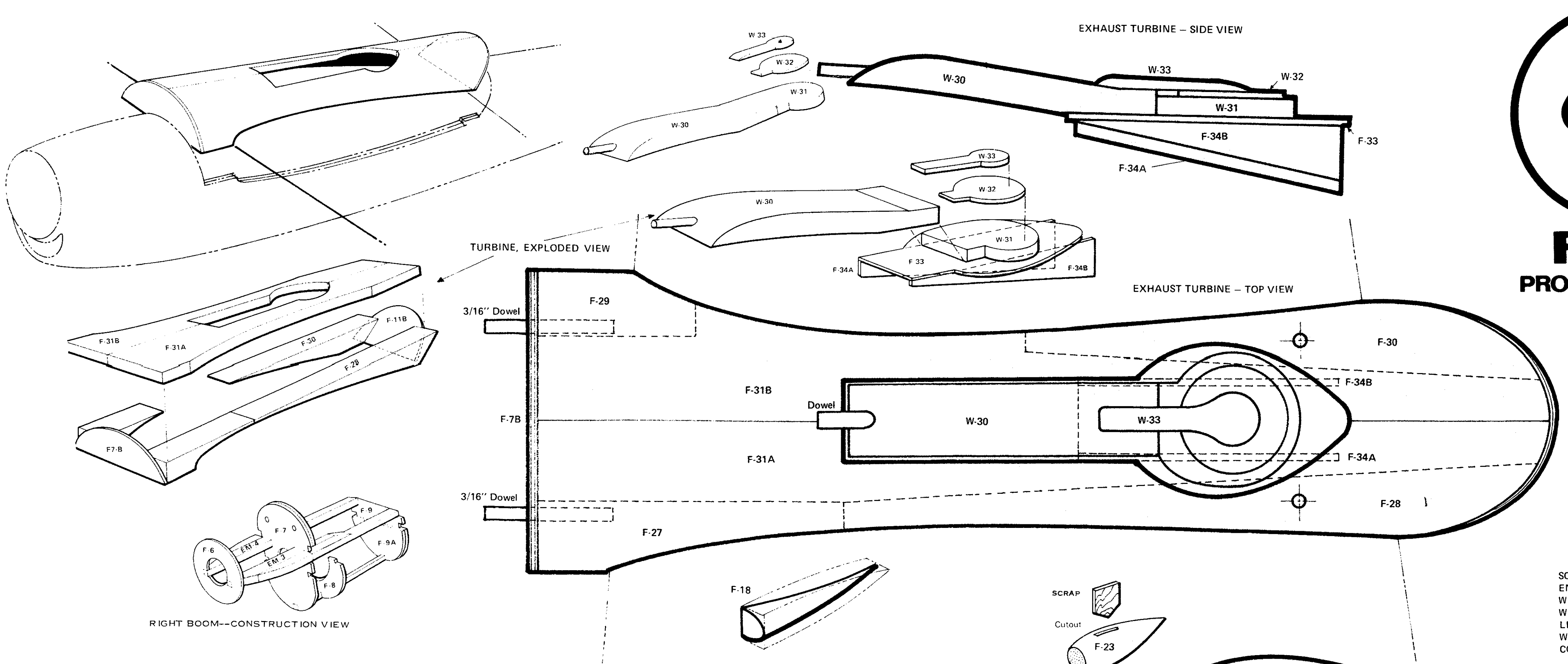

NOTE: Never use retract units must be used for main gear, since the P-38 gear retracts an into boom. It is necessary to immobilize steering arm on main gear installation.

NOTE TO THE "SCRATCH" BUILDER: Molded canopies, details, color and scale information, shown aluminum-covers (where applicable) are all available.

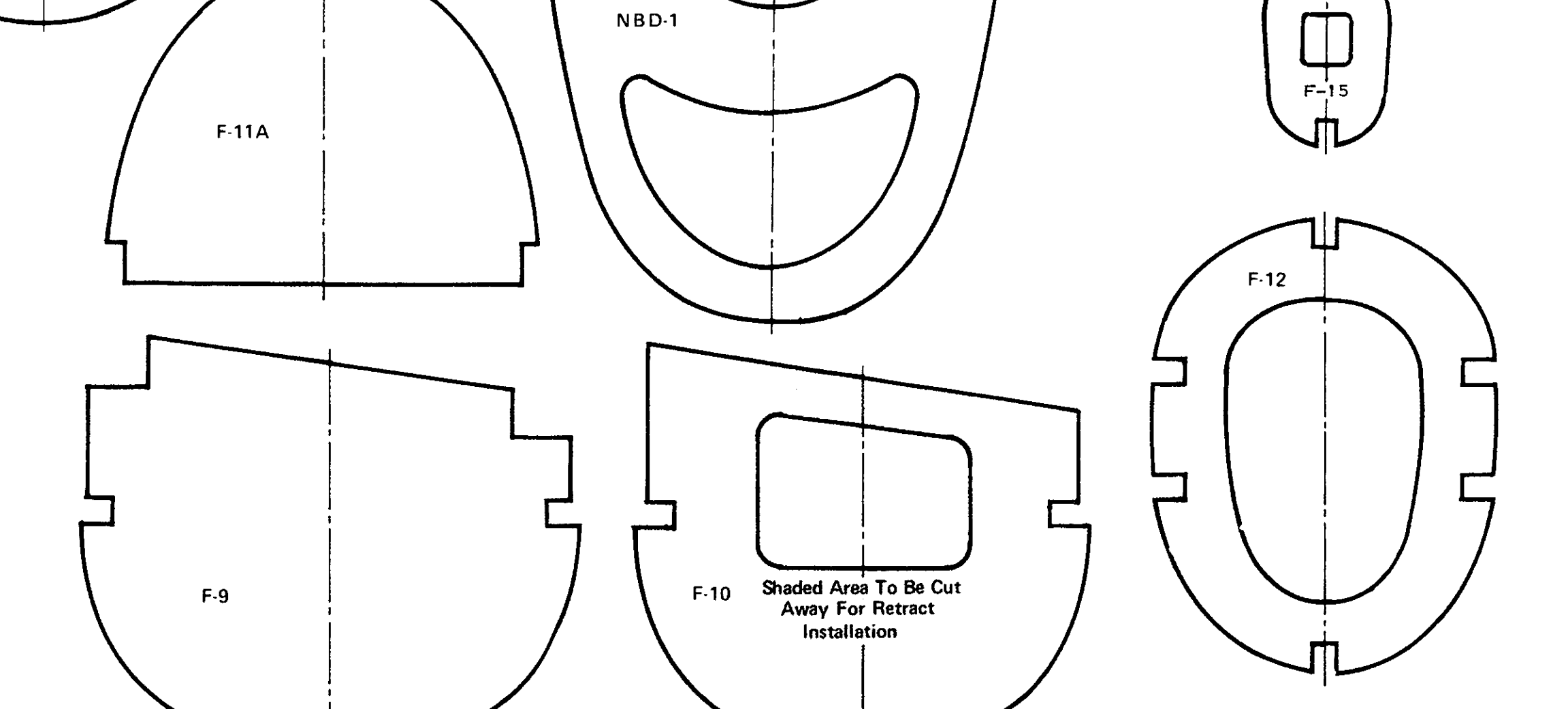
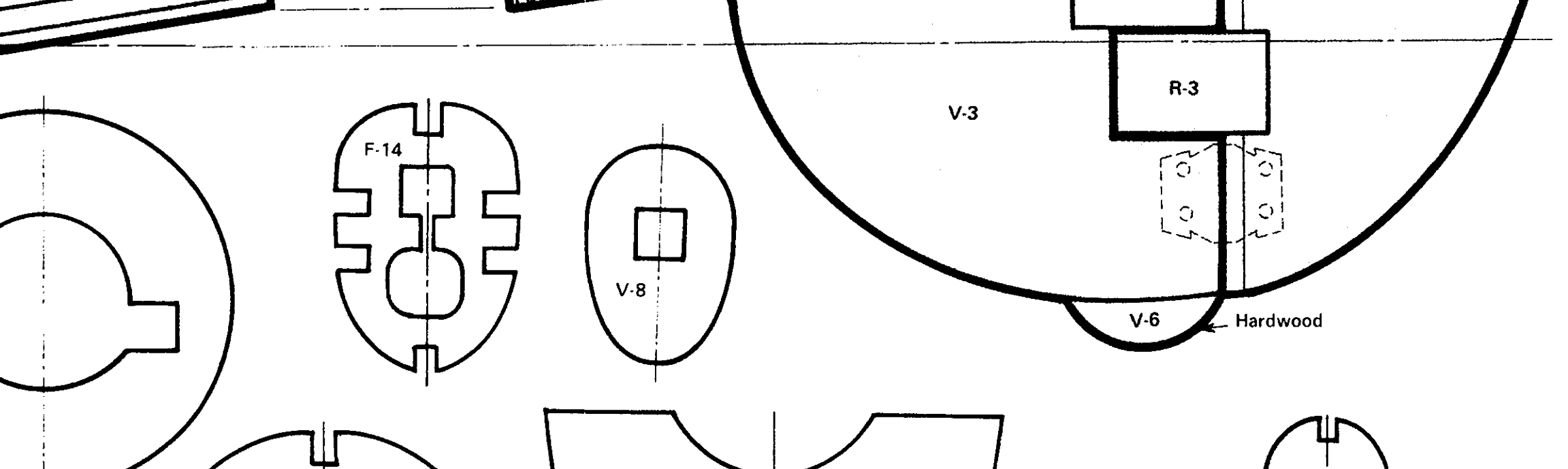
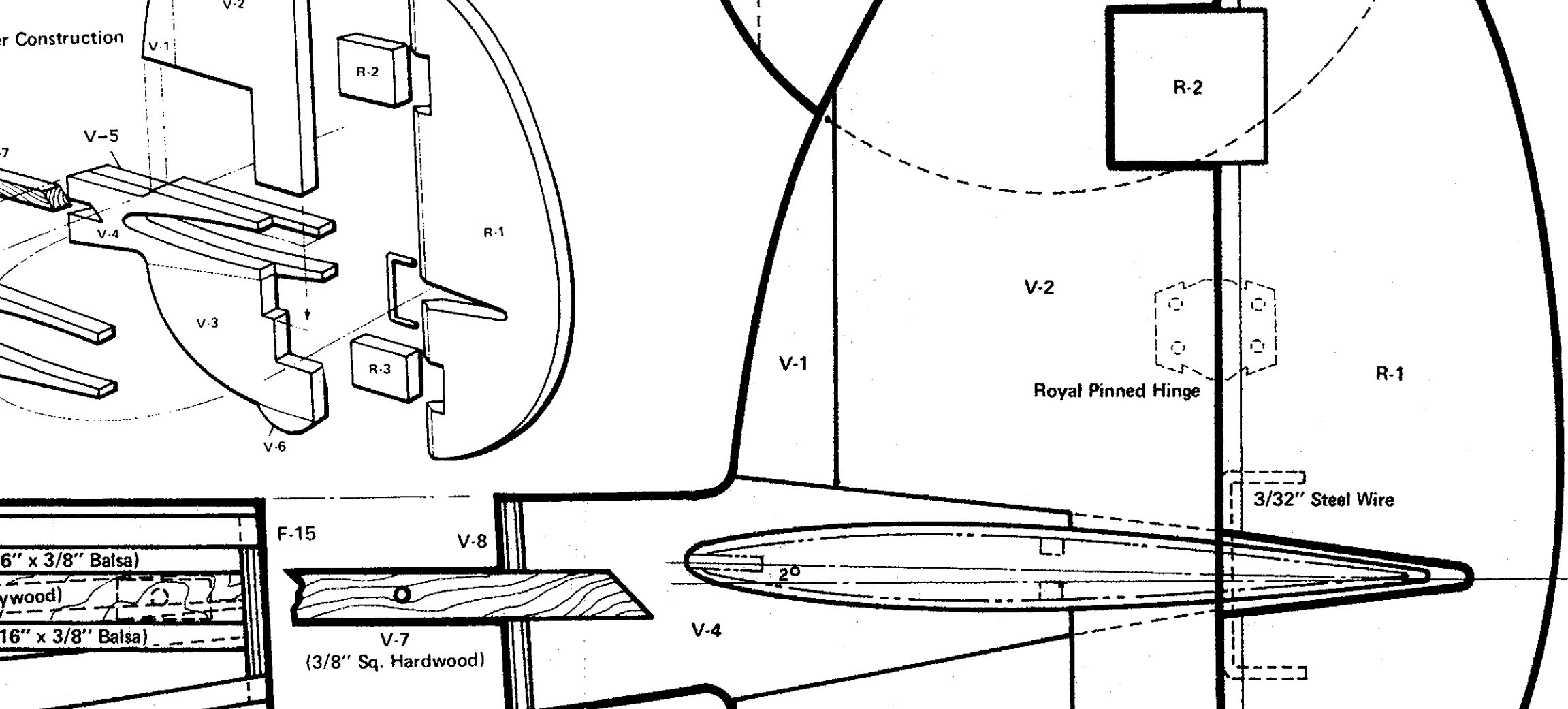
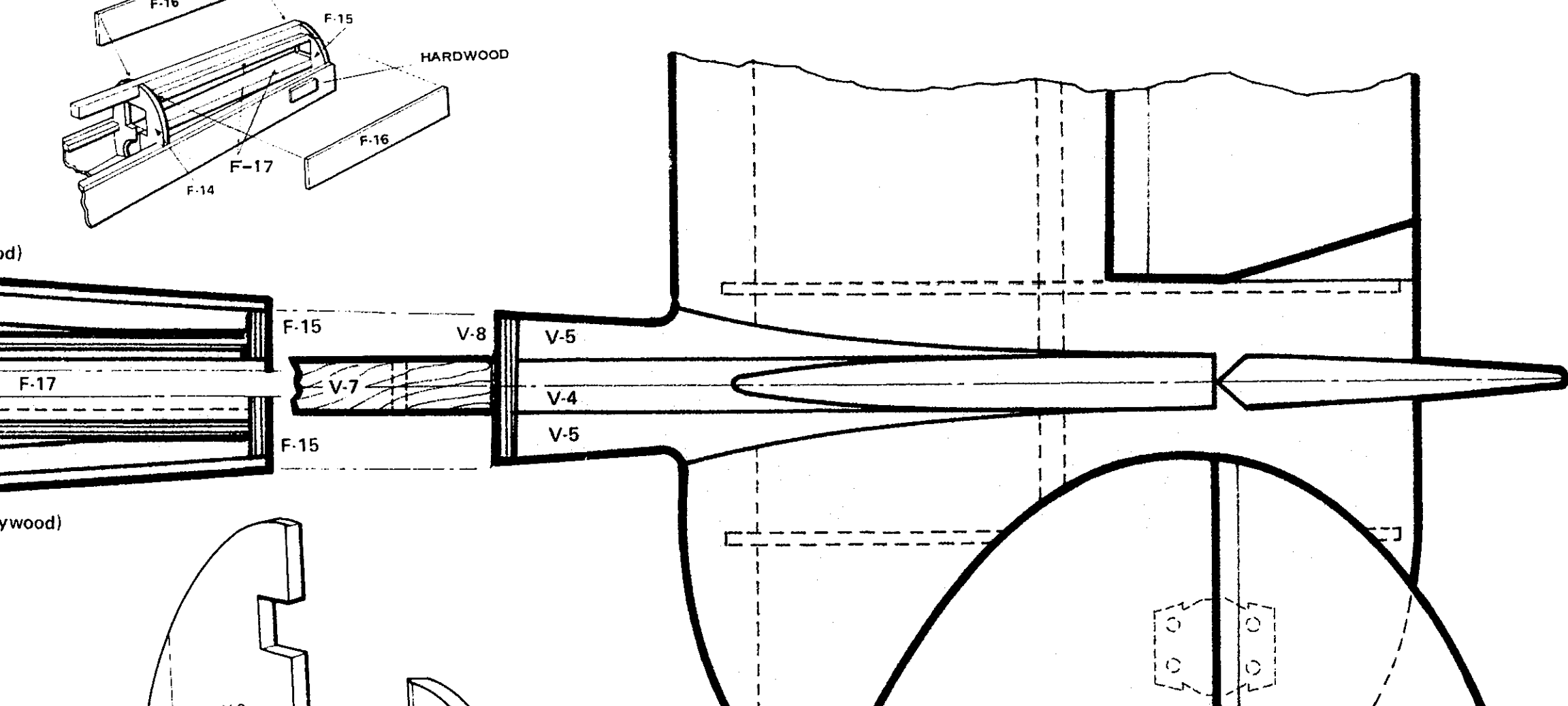
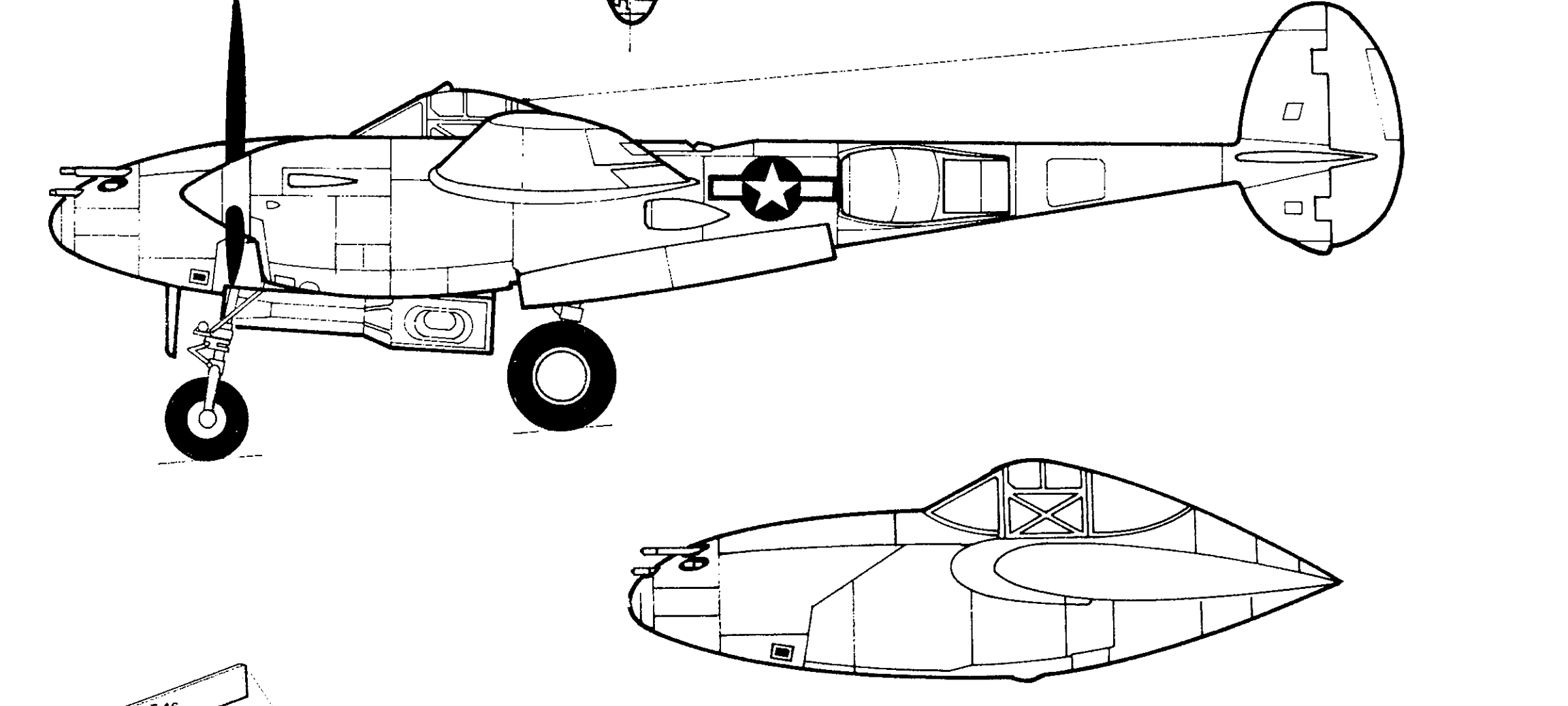
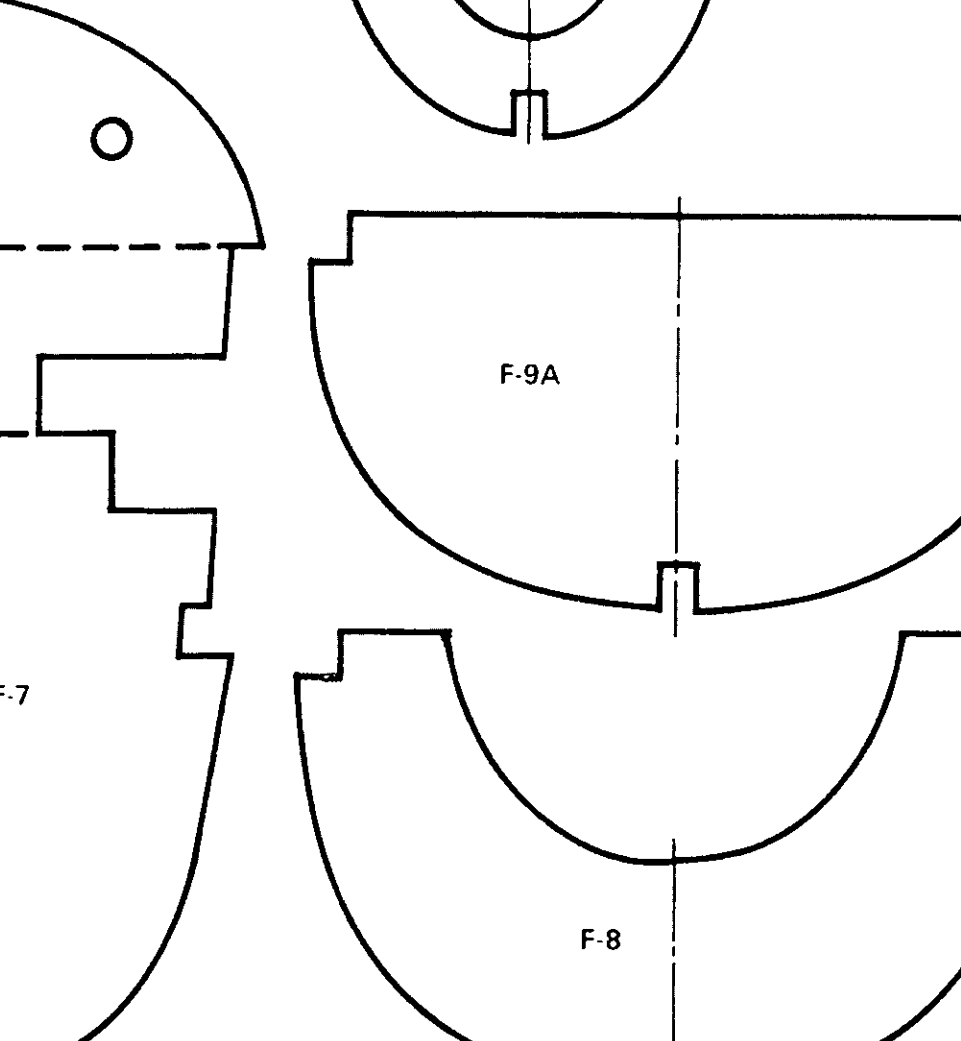
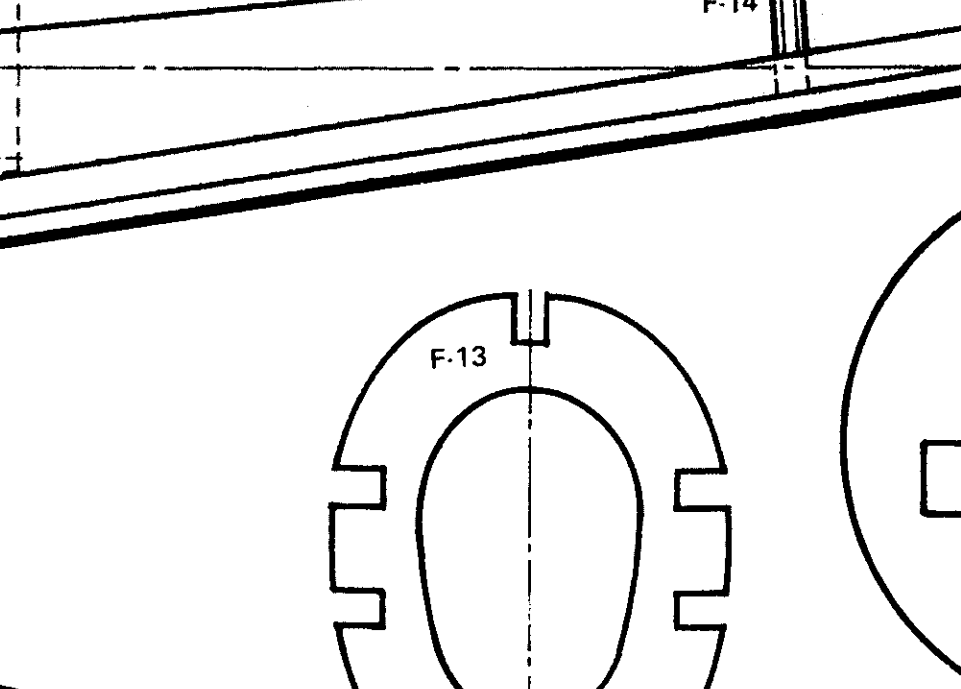
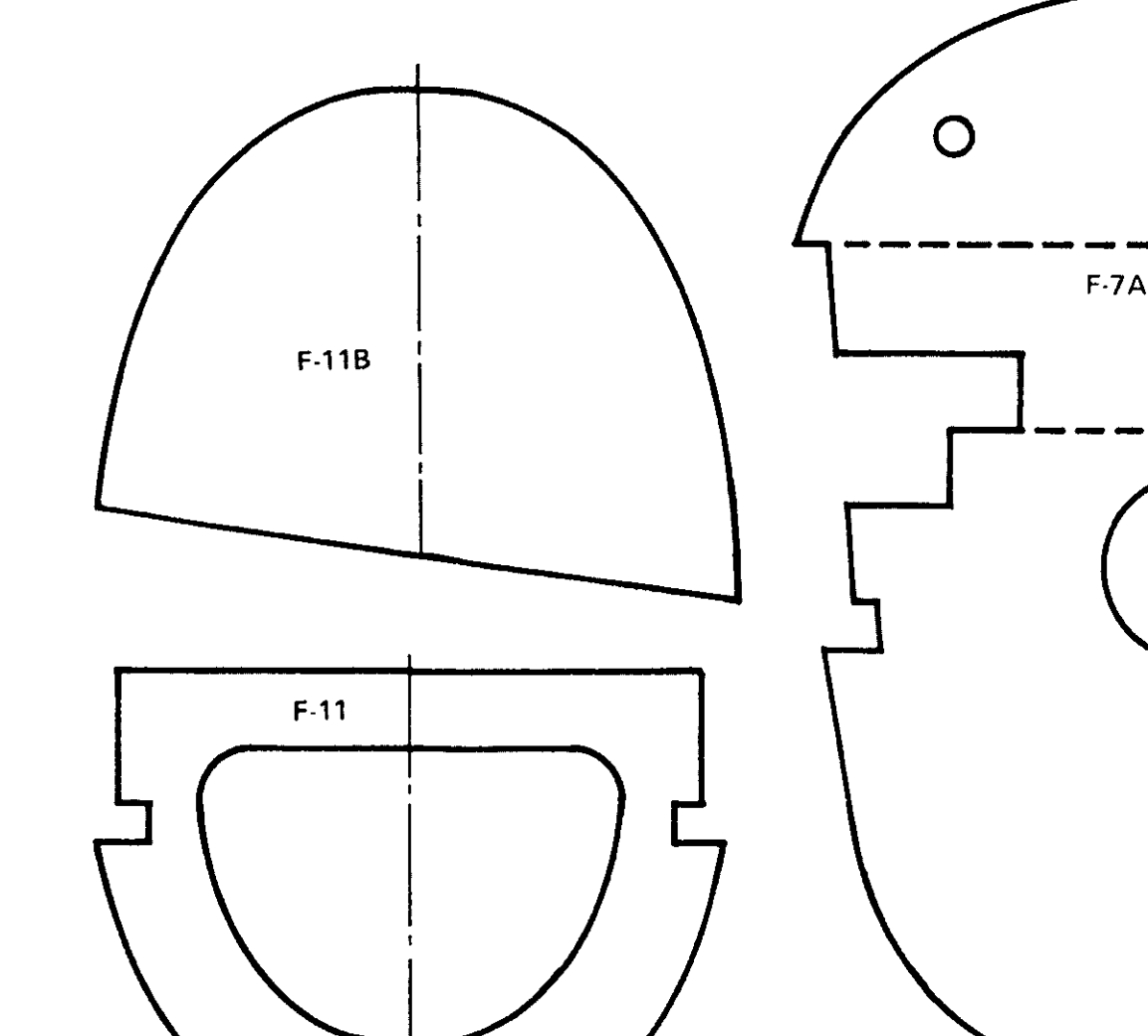
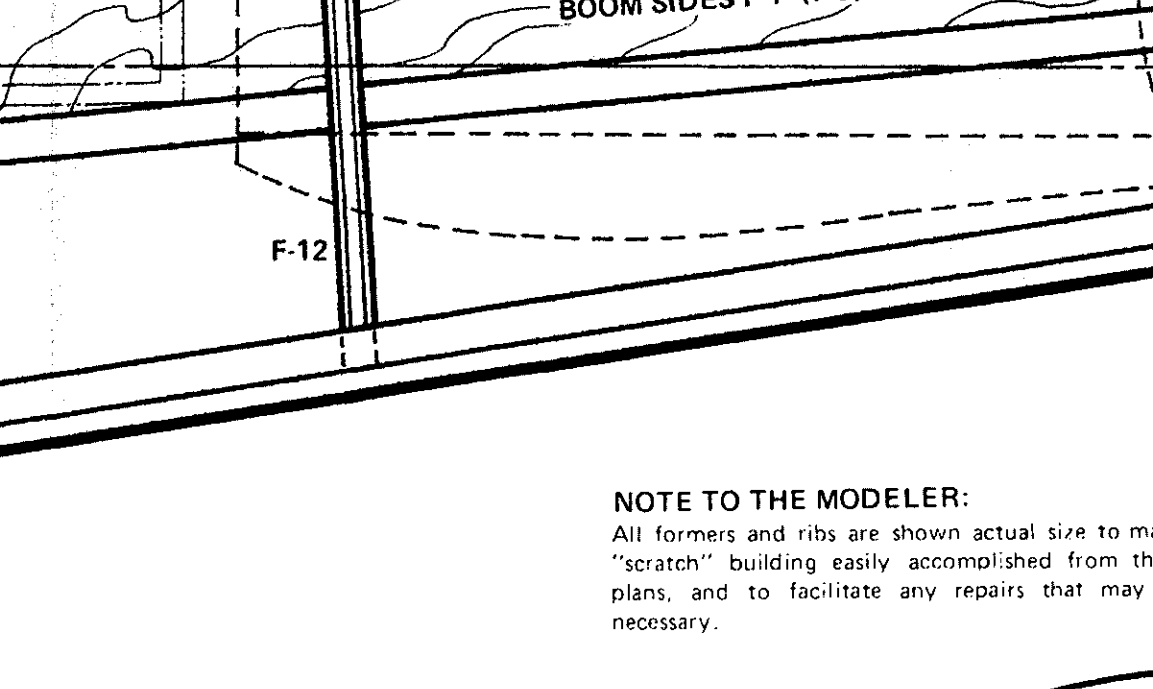
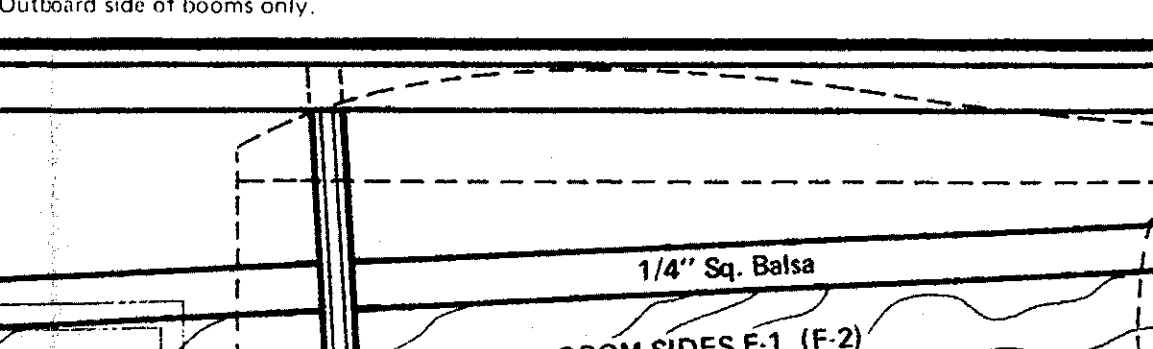
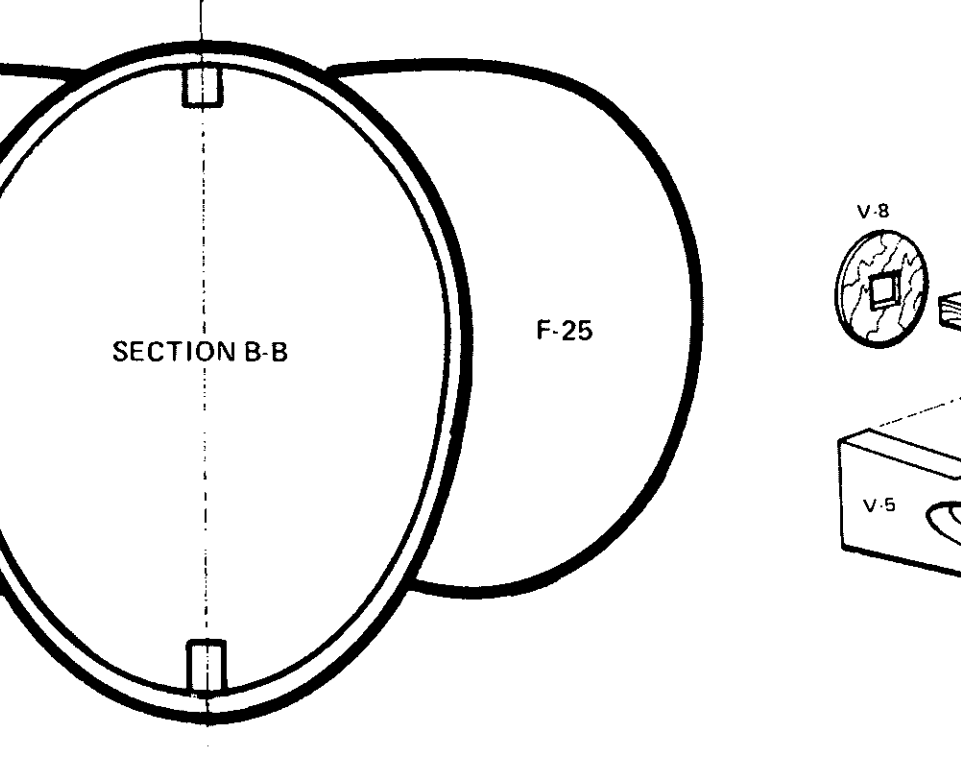
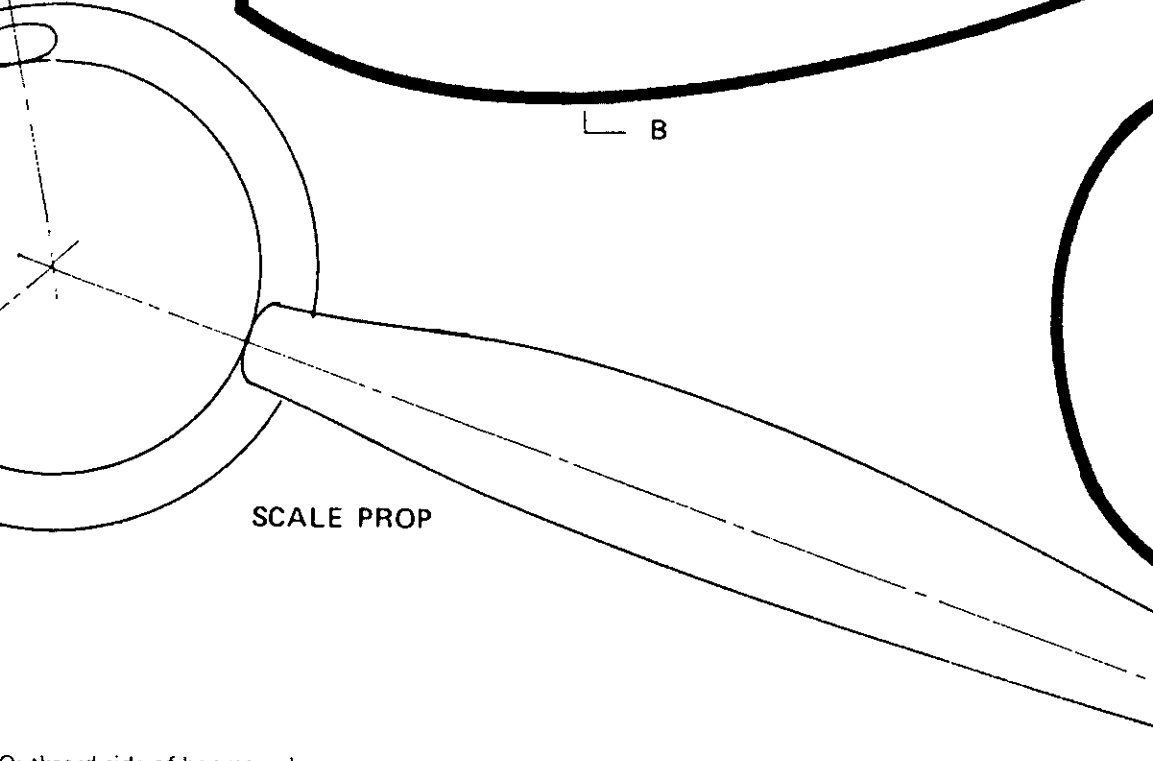

ROYAL PRODUCTS CORP.
LOCKHEED
P-38
Lightning

SHEET 2 of 2

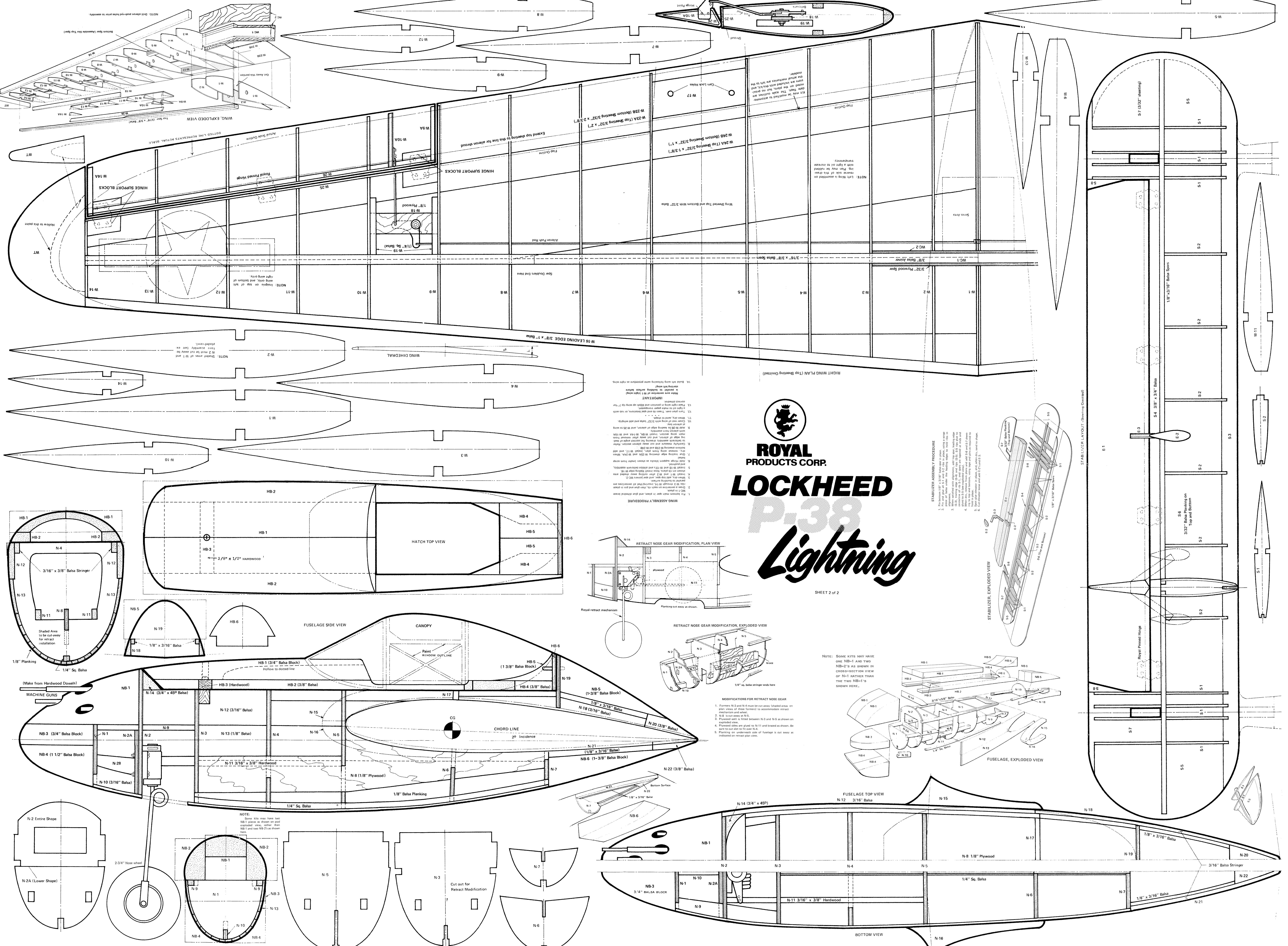

WING ASSEMBLY PROCEDURE

1. The fuselage is to be assembled in one piece, and the landing gear is to be assembled in one piece.
2. The fuselage is to be assembled in one piece, and the landing gear is to be assembled in one piece.
3. The fuselage is to be assembled in one piece, and the landing gear is to be assembled in one piece.
4. The fuselage is to be assembled in one piece, and the landing gear is to be assembled in one piece.
5. The fuselage is to be assembled in one piece, and the landing gear is to be assembled in one piece.
6. The fuselage is to be assembled in one piece, and the landing gear is to be assembled in one piece.
7. The fuselage is to be assembled in one piece, and the landing gear is to be assembled in one piece.
8. The fuselage is to be assembled in one piece, and the landing gear is to be assembled in one piece.
9. The fuselage is to be assembled in one piece, and the landing gear is to be assembled in one piece.
10. The fuselage is to be assembled in one piece, and the landing gear is to be assembled in one piece.
11. The fuselage is to be assembled in one piece, and the landing gear is to be assembled in one piece.
12. The fuselage is to be assembled in one piece, and the landing gear is to be assembled in one piece.
13. The fuselage is to be assembled in one piece, and the landing gear is to be assembled in one piece.
14. The fuselage is to be assembled in one piece, and the landing gear is to be assembled in one piece.

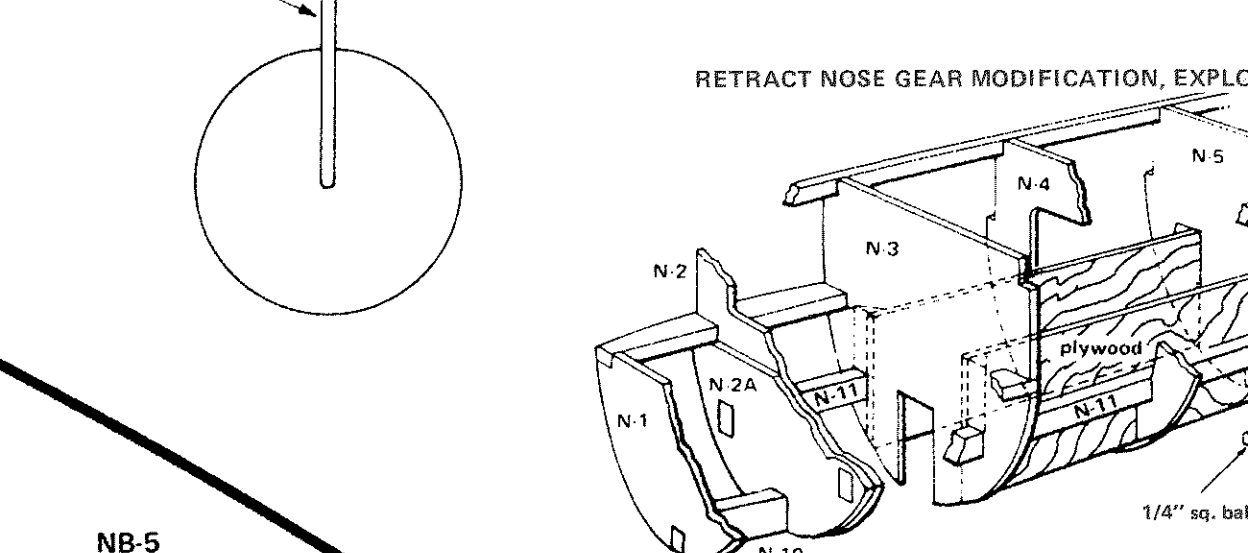
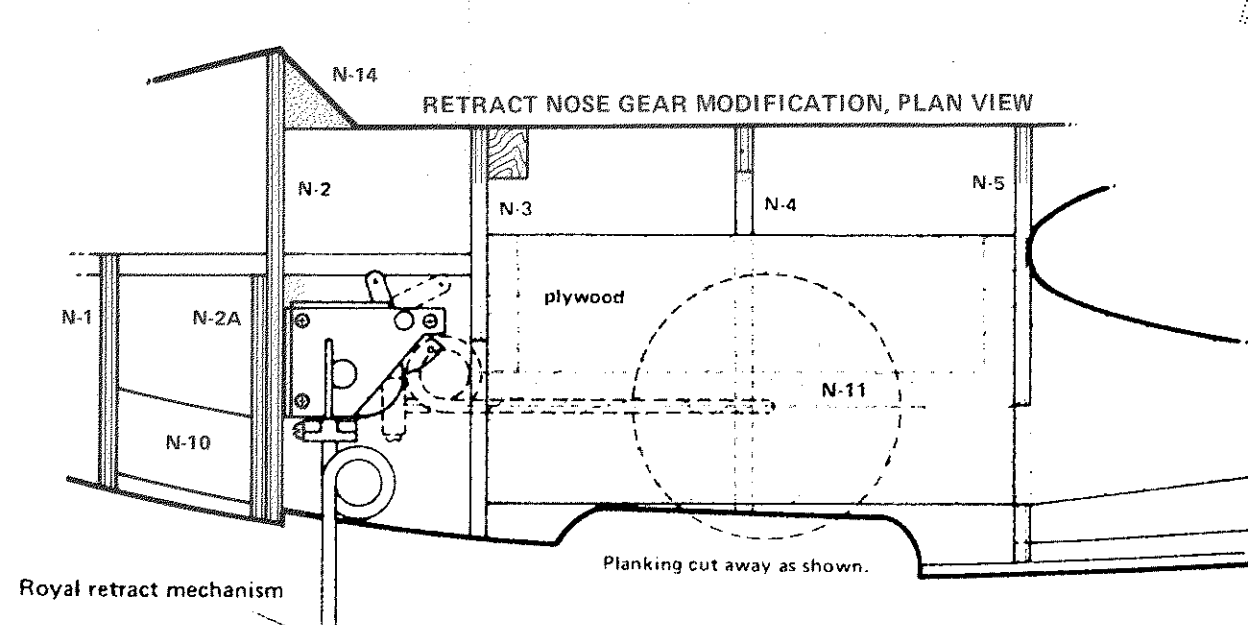

- MODIFICATIONS FOR RETRACT NOSE GEAR**
1. Formers N-3 and N-4 must be cut away (shaded areas on plan view of these formers) to accommodate retract mechanism and axle.
 2. N-5 is cut away at S.S.
 3. Plywood web is fitted between N-3 and N-5 as shown on exploded view.
 4. Plywood sides are glued to N-11 and braced as shown. Be sure to cut slots in N-5 and N-6.
 5. Plywood on underside side of fuselage is cut away as indicated on retract gear view.

NOTE: SOME KITS MAY HAVE ONE NB-1 AND TWO NB-2'S AS SHOWN IN CROSS-SECTION VIEW OF N-1 RATHER THAN THE TWO NB-1'S SHOWN HERE.

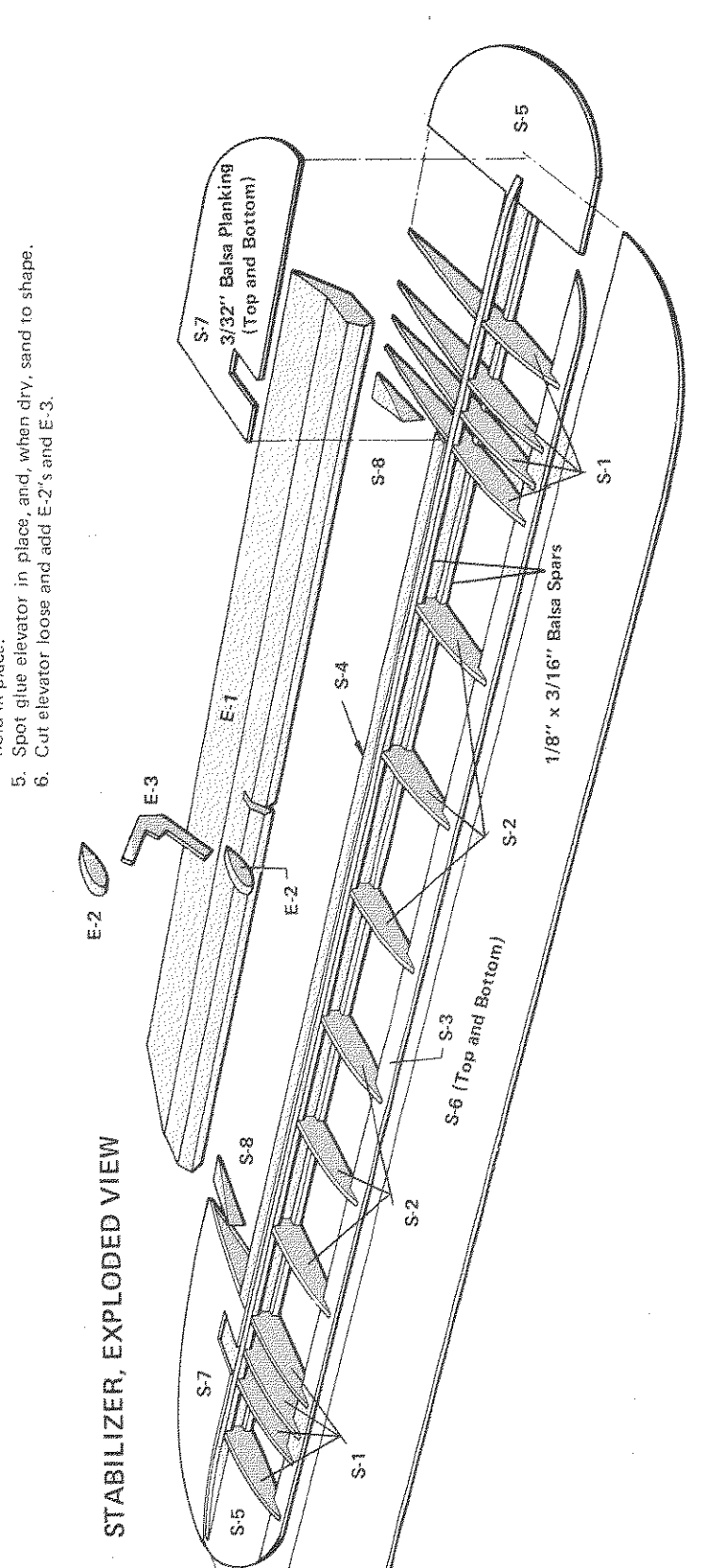
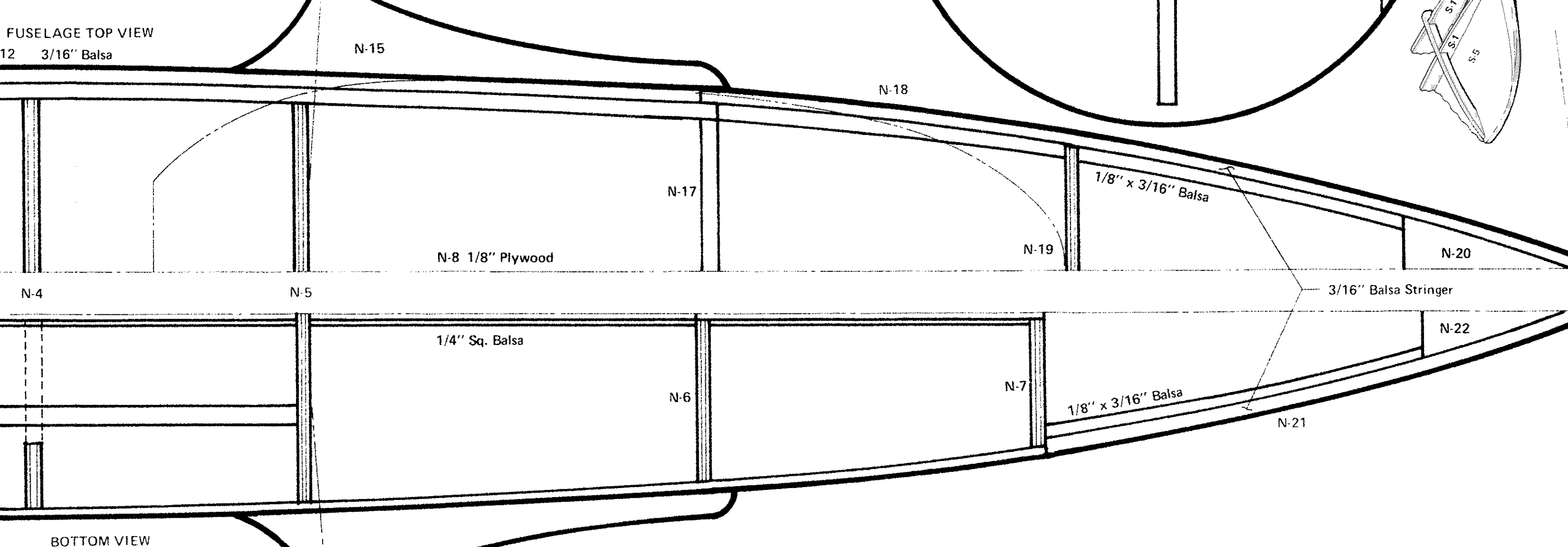
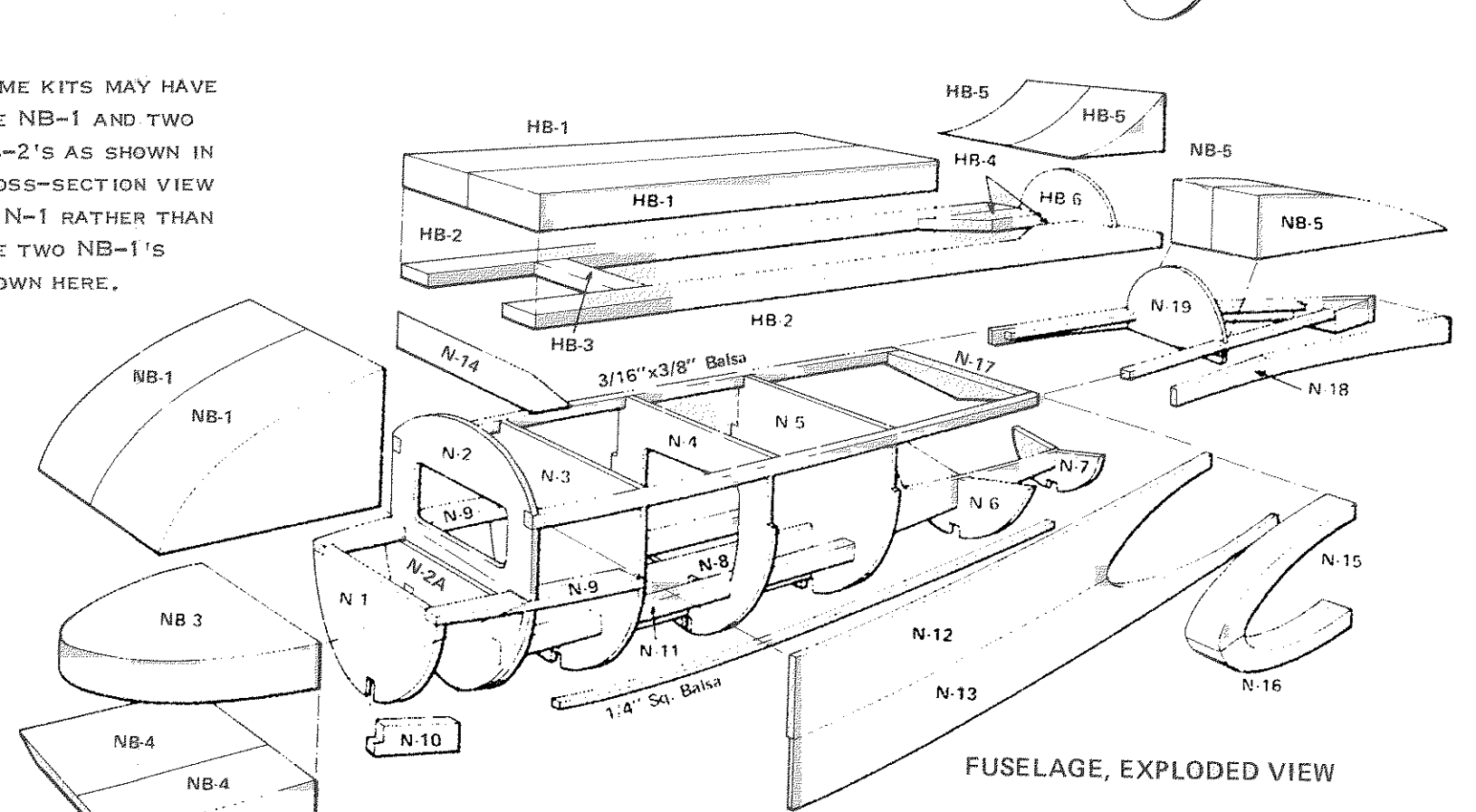

STABILIZER LAYOUT (Shoring Omitted)

